

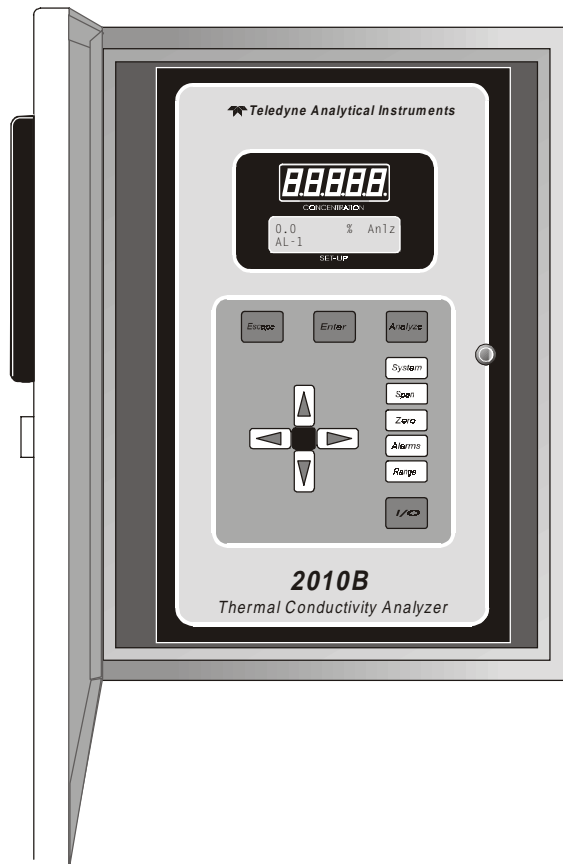

OPERATING INSTRUCTIONS FOR

Model 2010B

Thermal Conductivity Analyzer



	DANGER	
<p>HIGHLY TOXIC AND OR FLAMMABLE LIQUIDS OR GASES MAY BE PRESENT IN THIS MONITORING SYSTEM.</p> <p>PERSONAL PROTECTIVE EQUIPMENT MAY BE REQUIRED WHEN SERVICING THIS SYSTEM.</p> <p>HAZARDOUS VOLTAGES EXIST ON CERTAIN COMPONENTS INTERNALLY WHICH MAY PERSIST FOR A TIME EVEN AFTER THE POWER IS TURNED OFF AND DISCONNECTED.</p> <p>ONLY AUTHORIZED PERSONNEL SHOULD CONDUCT MAINTENANCE AND/OR SERVICING. BEFORE CONDUCTING ANY MAINTENANCE OR SERVICING CONSULT WITH AUTHORIZED SUPERVISOR/MANAGER.</p>		

P/N M70845
11/22/00
ECO # 00-0517

Copyright © 1998 Teledyne Analytical Instruments

All Rights Reserved. No part of this manual may be reproduced, transmitted, transcribed, stored in a retrieval system, or translated into any other language or computer language in whole or in part, in any form or by any means, whether it be electronic, mechanical, magnetic, optical, manual, or otherwise, without the prior written consent of Teledyne Analytical Instruments, 16830 Chestnut Street, City of Industry, CA 91749-1580.

Warranty

This equipment is sold subject to the mutual agreement that it is warranted by us free from defects of material and of construction, and that our liability shall be limited to replacing or repairing at our factory (without charge, except for transportation), or at customer plant at our option, any material or construction in which defects become apparent within one year from the date of shipment, except in cases where quotations or acknowledgments provide for a shorter period. Components manufactured by others bear the warranty of their manufacturer. This warranty does not cover defects caused by wear, accident, misuse, neglect or repairs other than those performed by Teledyne or an authorized service center. We assume no liability for direct or indirect damages of any kind and the purchaser by the acceptance of the equipment will assume all liability for any damage which may result from its use or misuse.

We reserve the right to employ any suitable material in the manufacture of our apparatus, and to make any alterations in the dimensions, shape or weight of any parts, in so far as such alterations do not adversely affect our warranty.

Important Notice

This instrument provides measurement readings to its user, and serves as a tool by which valuable data can be gathered. The information provided by the instrument may assist the user in eliminating potential hazards caused by his process; however, it is essential that all personnel involved in the use of the instrument or its interface, with the process being measured, be properly trained in the process itself, as well as all instrumentation related to it.

The safety of personnel is ultimately the responsibility of those who control process conditions. While this instrument may be able to provide early warning of imminent danger, it has no control over process conditions, and it can be misused. In particular, any alarm or control systems installed must be tested and understood, both as to how they operate and as to how they can be defeated. Any safeguards required such as locks, labels, or redundancy, must be provided by the user or specifically requested of Teledyne at the time the order is placed.

Therefore, the purchaser must be aware of the hazardous process conditions. The purchaser is responsible for the training of personnel, for providing hazard warning methods and instrumentation per the appropriate standards, and for ensuring that hazard warning devices and instrumentation are maintained and operated properly.

Teledyne Analytical Instruments, the manufacturer of this instrument, cannot accept responsibility for conditions beyond its knowledge and control. No statement expressed or implied by this document or any information disseminated by the manufacturer or its agents, is to be construed as a warranty of adequate safety control under the user's process conditions.

Table of Contents

Specific Model Information iv
Part I: Control Unit, Model 2010B Part I: 1-1
Part II: Analysis Unit, Model 2010B Part II: 1-1
Appendix A-1

Specific Model Information

The instrument for which this manual was supplied may incorporate one or more options not supplied in the standard instrument. Commonly available options are listed below, with check boxes. Any that are incorporated in the instrument for which this manual is supplied are indicated by a check mark in the box.

Instrument Serial Number: _____

Options Included in the Instrument with the Above Serial Number:

- C:** Auto Calibration valves (zero/span/sample) built-in gas control valves are electronically controlled to provide synchronization with the analyzer's operations.
- G:** Stainless steel cell block with nickel filaments and Stainless Steel fittings and tubing.
- H:** Stainless steel cell block with gold filaments for corrosive gas streams and Stainless Steel fittings and tubing.
- K:** 19" Rack Mount option with one or two analyzer Control Units installed and ready to mount in a standard rack.
- K2:** 19" Rack Mount option with two Control Units mounted.
- K3:** 19" Rack Mount option with one Control Unit mounted and a blank cover installed in the second Control Unit location.
- L:** Gas selector panel consisting of sample/ref flow meters and control valves for metering input of sample/calibrations support gases.
- F:** Flame Arrestors for Class 1, Div. 1, Groups C/D service.
- P:** Flame Arrestors for Class 1, Div. 1, Groups C/D service, and Auto Cal valves option (Ref. C above) and GP use.
- Q:** Flame Arrestors for Group B (hydrogen) service, and Auto Cal valves option (Ref. C above)
- O:** Flame Arrestors for Group B (hydrogen)
- R:** Sealed Reference Cell

Table of Contents

1 Introduction

1.1 Overview 1-1

1.2 Typical Applications 1-2

1.3 Main Features of the Analyzer 1-2

1.4 Model Designations 1-3

1.5 Operator Interface (Front Panel) 1-3

1.6 Recognizing Difference Between LCD & VFD 1-5

1.7 Equipment Interface (Rear Panel) 1-5

1.8 Gas Connections 1-7

2 Operational Theory

2.1 Introduction 2-1

2.2 Sensor Theory 2-1

 2.2.1 Sensor Configuration 2-1

 2.2.2 Calibration 2-2

 2.2.3 Effects of Flowrate and Gas Density 2-3

 2.2.4 Measurement Results 2-3

2.3 Electronics and Signal Processing 2-3

2.4 Temperature Control 2-5

3 Installation

3.1 Unpacking the Analyzer 3-1

3.2 Mounting the Control Unit 3-1

3.3 Electrical Connections (Rear Panel) 3-3

 3.3.1 Primary Input Power 3-4

 3.3.2 Fuse Installation 3-4

 3.3.3 Analog Outputs 3-4

 3.3.4 Alarm Relays 3-6

 3.3.5 Digital Remote Cal Inputs 3-7

 3.3.6 Range ID Relays 3-8

 3.3.7 Network I/O 3-8

 3.3.8 RS-232 Port 3-9

 3.3.9 Remote Probe Connector 3-9

3.4 Testing the System 3-16

3.5 Warm Up at Power Up 3-16

4 Operation

4.1 Introduction 4-1

4.2 Using the Data Entry and Function Buttons 4-1

- 4.3 The *System* Function 4-4
 - 4.3.1 Setting the Display 4-5
 - 4.3.2 Setting up an Auto-Cal 4-5
 - 4.3.3 Password Protection 4-6
 - 4.3.3.1 Entering the Password 4-7
 - 4.3.3.2 Installing or Changing the Password 4-7
 - 4.3.4 Logging Out 4-9
 - 4.3.5 System Self-Diagnostic Test 4-9
 - 4.3.6 The Model Screen 4-10
 - 4.3.7 Checking Linearity with Algorithm 4-10
- 4.4 The *Zero* and *Span* Functions 4-11
 - 4.4.1 Zero Cal 4-12
 - 4.4.1.1 Auto Mode Zeroing 4-12
 - 4.4.1.2 Manual Mode Zeroing 4-13
 - 4.4.1.3 Cell Failure 4-14
 - 4.4.2 Span Cal 4-14
 - 4.4.2.1 Auto Mode Spanning 4-15
 - 4.4.2.2 Manual Mode Spanning 4-15
- 4.5 The *Alarms* Function 4-16
- 4.6 The *Range* Select Function 4-18
 - 4.6.1 Manual (Select/Define Range) Screen 4-19
 - 4.6.2 Auto (Single Application) Screen 4-19
 - 4.6.3 Precautions 4-21
- 4.7 The *Analyze* Function 4-21
- 4.8 Programming 4-22
 - 4.8.1 The Set Range Screen 4-23
 - 4.8.2 The Curve Algorithm Screen 4-25
 - 4.8.2.1 Checking the Linearization 4-25
 - 4.8.2.2 Manual Mode Linearization 4-26
 - 4.8.2.3 Auto Mode Linearization 4-27
- 4.9 Special Function Setup 4-28
 - 4.9.1 Output Signal Reversal 4-28
 - 4.9.2 Special - Inverting Output 4-28
 - 4.9.3 Special - Polarity Coding 4-29
 - 4.9.4 Special - Nonlinear Application Gain Preset 4-29

Maintenance

- 5.1 Routine Maintenance 5-1
- 5.2 System Self Diagnostic Test 5-1
- 5.3 VFD Display 5-2
- 5.4 Fuse Replacement 5-2

5.5 Major Internal Components 5-3
5.6 Cleaning 5-5
5.7 Phone Numbers 5-5

Appendix

A-1 Specifications A-1
A-2 Recommended 2-Year Spare Parts List A-3
A-3 Drawing List A-4



The customer should ensure that the principles of operating of this equipment are well understood by the user. Misuse of this product in any manner, tampering with its components, or unauthorized substitution of any component may adversely affect the safety of this instrument.

Since the use of this instrument is beyond the control of Teledyne, no responsibility by Teledyne, its affiliates, and agents for damage or injury from misuse or neglect of this equipment is implied or assumed.

Introduction

1.1 Overview

The Model 2010 is a family of split configuration conductivity analyzers. Each analyzer consist of a Control Unit suitable for installation in a general purpose area-enclosure rated NEMA-4, and a Analysis Unit which is housed in an explosion-proof enclosure. The Analysis Unit enclosure is rated for NEMA 4/7 Class I, Div. 1, Groups B,C,D and is approved by U/L and CSA.

The Analytical Instruments Model 2010B Thermal Conductivity Analyzer is a versatile microprocessor-based instrument for measuring a component gas in a background gas, or in a specific mixture of background gases. It compares the thermal conductivity of a sample stream with that of a reference gas of known composition. The 2010B can—

- measure the concentration of one gas in a mixture of two gases.
- measure the concentration of a gas in a specific mixture of background gases.
- measure the purity of a sample stream containing a single impurity or a mixture of impurities.

The standard 2010B is pre-programmed with automatic linearization algorithms for a large number of gases and gas mixtures. The factory can add to this data base for custom applications, and the sophisticated user can add his own unique applications.

This manual section covers the Model 2010B General Purpose flush-panel and rack-mount control units only.

Many of the Model 2010B features covered in this manual are optional, selected according to the customers specific application. Refer to the specific model information sheet (page IV) for the options incorporated in the instrument.

1.2 Typical Applications

A few typical applications of the Model 2010B are:

- Power generation
- Air liquefaction
- Chemical reaction monitoring
- Steel manufacturing and heat treating
- Petrochemical process control
- Quality assurance
- Refrigeration and storage
- Gas proportioning control.

1.3 Main Features of the Analyzer

The main features of the Model 2010B Thermal Conductivity Analyzer include:

- Three independent, user definable, analysis ranges allow up to three different gas applications with one concentration range each, or up to three concentration ranges for a single gas application, or any combination.
- Special recalibration range for multiple applications. Recalibrating one, recalibrates all.
- Automatic, independent linearization for each range.
- Auto Ranging allows analyzer to automatically select the proper preset range for a given single application. Manual override allows the user to lock onto a specific range of interest.
- RS-232 serial digital port for use with a computer or other digital communications device.
- Six adjustable concentration set points with two alarms and a system failure alarm relay.
- Extensive self-diagnostic testing, at startup and on demand.
- A 2-line alphanumeric display screen, driven by microprocessor electronics, that continuously prompts and informs the operator.
- High resolution, accurate indication of target or impurity gas concentration from large, bright, meter readout. (0-9999 ppm through 0-100 % depending on types of gas involved.)
- Standard, proven sensor cell design.

- Wide range of custom applications, ranges, and linearization.
- Microprocessor based electronics: 8-bit CMOS microprocessor with 32 kB RAM and 128 kB ROM.
- Auto and remote calibration capabilities.
- Four analog outputs: two for measurement (0–1 V dc and Isolated 4–20 mA dc) and two for range identification.
- Compact and versatile design: Small footprint, yet internal components are accessible.

1.4 Model Designations

The Model 2010B is ordinarily custom programmed at the factory to fit the customer's application. Many parameters, including the number of channels, the gas application, the materials specification of the sampling system, and others, are options. The most common options, are covered in this manual. See the *Specific Model Information* checklist in the front matter of this manual for those that apply to your Model 2010B analyzer. Some standard models that are not covered in this manual are listed here.

Models 2000A: Both analysis section and control unit are in a single general purpose enclosure.

Models 2020: Both the analysis section and control unit are in a single explosion proof enclosure.

1.5 Operator Interface (Front Panel)

The standard 2010B is housed in a rugged metal case with all controls and displays accessible from the front panel. See Figure 1-1. The front panel has thirteen buttons for operating the analyzer, a digital meter, and an alphanumeric display. They are described briefly here and in detail in the *Operations* chapter of this manual.

Function Keys: Six touch-sensitive membrane switches are used to change the specific function performed by the analyzer:

- **Analyze** Perform analysis for target-gas content of a sample gas.
- **System** Perform system-related tasks (described in detail in chapter 4, *Operation*.).

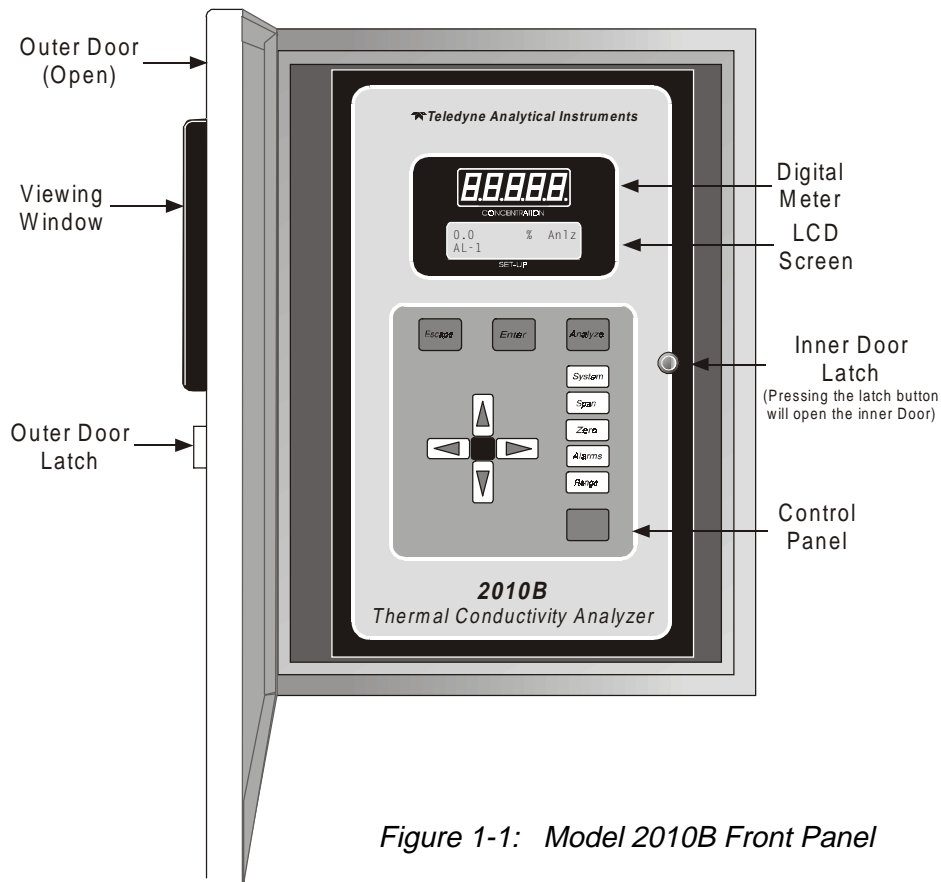

Figure 1-1: Model 2010B Front Panel

- **Span** Span calibrate the analyzer.
- **Zero** Zero calibrate the analyzer.
- **Alarms** Set the alarm setpoints and attributes.
- **Range** Set up the user definable ranges for the instrument.

Data Entry Keys: Six touch-sensitive membrane switches are used to input data to the instrument via the alphanumeric VFD (Vacuum Fluorescent Display) display:

- **Left & Right Arrows** Select between functions currently displayed on the VFD screen.
- **Up & Down Arrows** Increment or decrement values of functions currently displayed.
- **Enter** Moves VFD on to the next screen in a series. If none remains, returns to the *Analyze* screen.
- **Escape** Moves VFD back to the previous screen in a series. If none remains, returns to the *Analyze* screen.

Digital Meter Display: The meter display is a VFD device that produces large, bright, 7-segment numbers that are legible in any lighting. It produces a continuous trace readout from 0-9999 ppm or a continuous percent readout from 1-100 %. It is accurate across all analysis ranges.

Alphanumeric Interface Screen: The VFD screen is an easy-to-use interface between operator and analyzer. It displays values, options, and messages that give the operator immediate feedback.

 **Standby Button:** The *Standby* turns off the display and outputs, but circuitry is still operating.

CAUTION: *The power cable must be unplugged to fully disconnect power from the instrument. When chassis is exposed or when access door is open and power cable is connected, use extra care to avoid contact with live electrical circuits.*



Access Door: For access to the thermal conductivity sensor or the front panel electronics, the front panel swings open when the latch in the upper right corner of the panel is pressed all the way in with a narrow gauge tool. Accessing the main electronics circuit board requires unfastening rear panel screws and sliding the electronics drawer out of the case. (See chapter 5.)

1.6 Recognizing Difference Between LCD & VFD

LCD (Liquid Crystal Display) has *GREEN* background with *BLACK* characters. VFD has *DARK* background with *GREEN* characters. In the case of VFD (Vacuum Fluorescent Display) - *NO CONTRAST ADJUSTMENT IS NEEDED*.

1.7 Equipment Interface (Rear Panel)

The rear panel, shown in Figure 1-2, contains the electrical connectors for external input and output. The connectors are described briefly here and in detail in chapter 3, *Installation*.

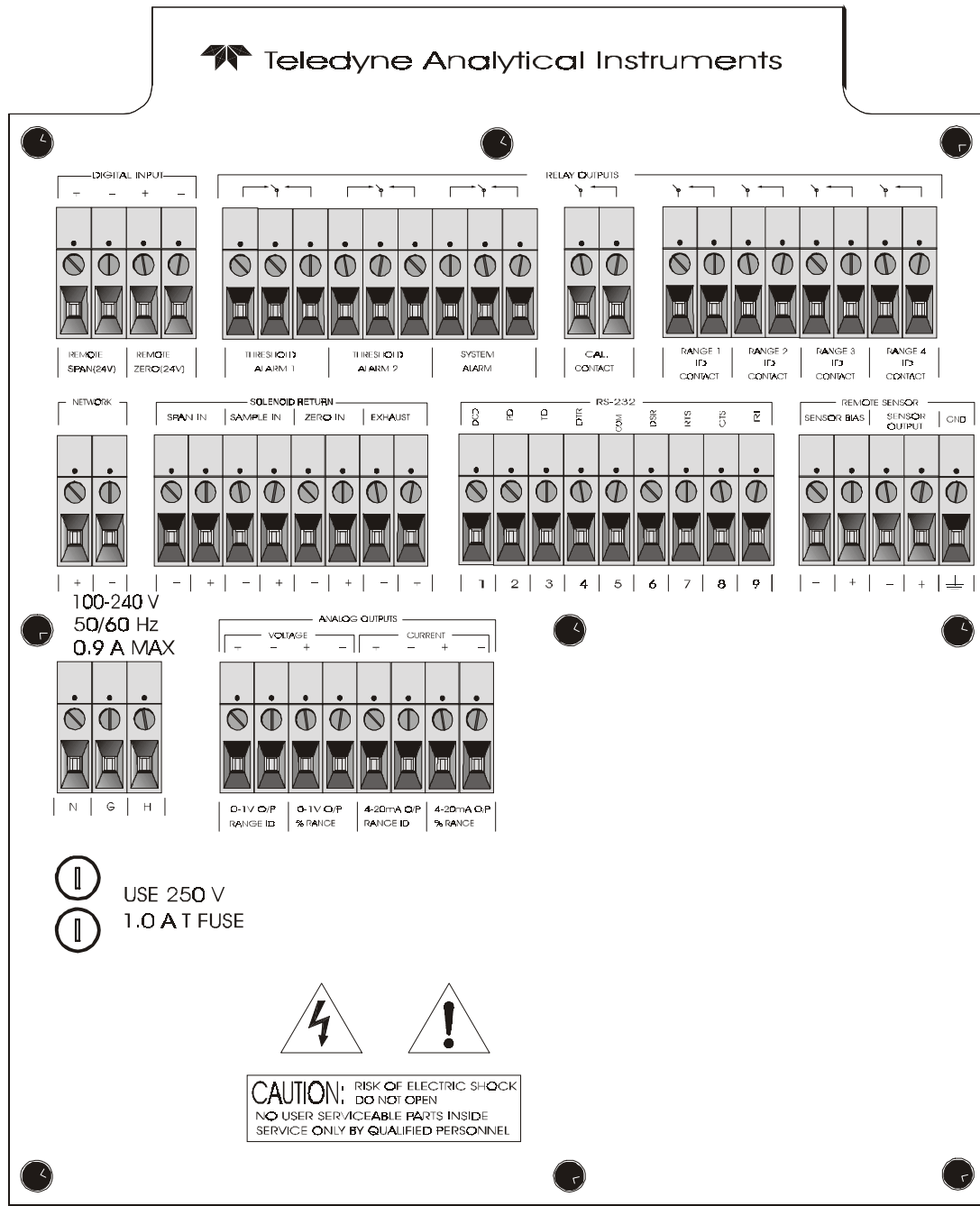

Figure 1-2: Model 2010B Rear Panel

- **Power Connection** 85-250 V AC power source.
- **Analog Outputs** 0-1 V dc concentration plus 0-1 V dc range ID, and isolated 4-20 mA dc plus 4-20 mA dc range ID.

-
- **Alarm Connections** 2 concentration alarms and 1 system alarm.
 - **RS-232 Port** Serial digital concentration signal output and control input.
 - **Remote Probe** Used in the 2010B to interface the external Analysis Unit.
 - **Remote Span/Zero** Digital inputs allow external control of analyzer calibration.
 - **Calibration Contact** To notify external equipment that instrument is being calibrated and readings are not monitoring sample.
 - **Range ID Contacts** Four separate, dedicated, range-identification relay contacts (01, 02, 03,CAL).
 - **Network I/O** Serial digital communications for local network access. For future expansion. Not implemented at this printing.

Note: If you require highly accurate Auto-Cal timing, use external Auto-Cal control where possible. The internal clock in the Model 2010B is accurate to 2-3 %. Accordingly, internally scheduled calibrations can vary 2-3 % per day.

Operational Theory

2.1 Introduction

The analyzer is composed of two subsystems:

1. Thermal Conductivity Sensor
2. Electronic Signal Processing, Display and Control.

The sensor is a thermal conductivity comparator that continuously compares the thermal conductivity of the sample gas with that of a reference gas having a known conductivity.

The electronic signal processing, display and control subsystem simplifies operation of the analyzer and accurately processes the sampled data. A microprocessor controls all signal processing, input/output, and display functions for the analyzer.

2.2 Sensor Theory

For greater clarity, Figure 2-1 presents two different illustrations, (a) and (b), of the operating principle of the thermal conductivity cell.

2.2.1 Sensor Configuration

The thermal conductivity sensor contains two chambers, one for the reference gas of known conductivity and one for the sample gas. Each chamber contains a pair of heated filaments. Depending on its thermal conductivity, each of the gases conducts a quantity of heat away from the filaments in its chamber. See Figure 2-1(a).

The resistance of the filaments depends on their temperature. These filaments are parts of the two legs of a Wheatstone bridge circuit that unbalances if the resistances of its two legs do not match. See Figure 2-1(b).

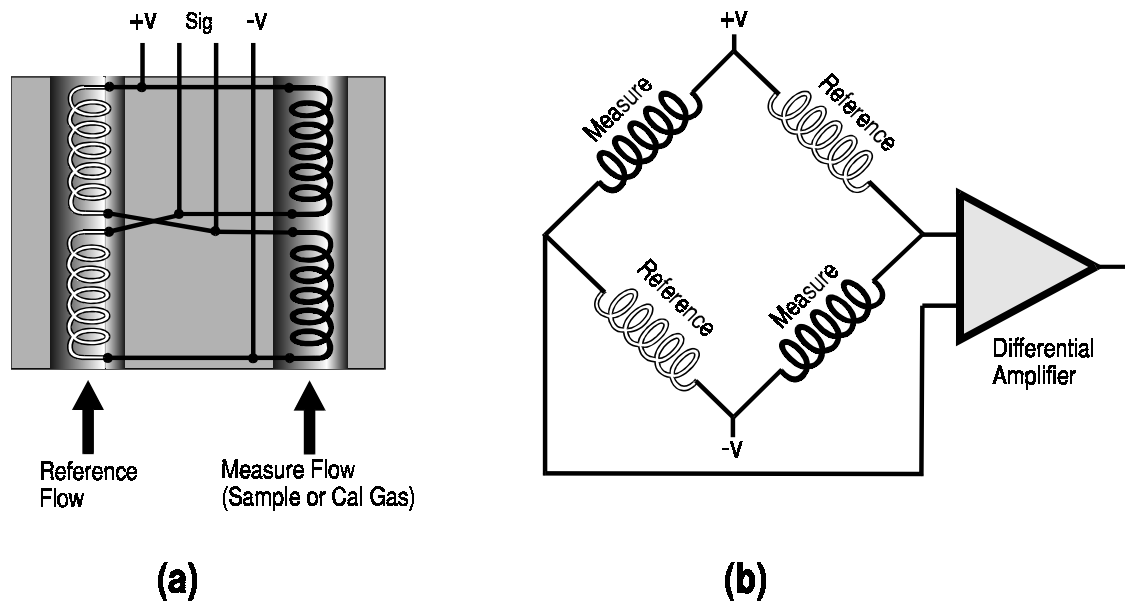

Figure 2-1: Thermal Conductivity Cell Operating Principle

If the thermal conductivities of the gases in the two chambers are different, the Wheatstone bridge circuit unbalances, causing a current to flow in its detector circuit. The amount of this current can be an indication of the amount of impurity in the sample gas, or even an indication of the type of gas, depending on the known properties of the reference and sample gases.

The temperature of the measuring cell is regulated to within 0.1 °C by a sophisticated control circuit. Temperature control is precise enough to compensate for diurnal effects in the output over the operating ranges of the analyzer. (See *Specifications* in the Appendix for details.)

2.2.2 Calibration

Because analysis by thermal conductivity is not an absolute measurement, calibration gases of **known composition** are required to fix the upper and lower parameters (“zero” and “span”) of the range, or ranges, of analysis. These gases must be used periodically, to check the **accuracy of the analyzer**.

During calibration, the bridge circuit is balanced, with zero gas against the reference gas, at one end of the measurement range; and it is sensitized with span gas against the reference gas at the other end of the measurement range. The resulting electrical signals are processed by the analyzer electronics to produce a standard 0-1V, or an isolated 4–20 mA dc, output signal, as described in the next section.

2.2.3 Effects of Flowrate and Gas Density

Because the flowrate of the gases in the chambers affects their cooling of the heated filaments, the flowrate in the chambers must be kept as equal, constant, and low as possible.

When setting the sample and reference flowrate, note that gases lighter than air will have an actual flowrate higher than indicated on the flowmeter, while gases heavier than air will have an actual flowrate lower than indicated. Due to the wide range of gases that are measured with the Thermal Conductivity Analyzer, the densities of the gases being handled may vary considerably.

Then, there are limited applications where the reference gas is in a sealed chamber and does not flow at all. These effects must be taken in consideration by the user when setting up an analysis.

2.2.4 Measurement Results

Thermal conductivity measurements are nonspecific by nature. This fact imposes certain limitations and requirements. If the user intends to employ the analyzer to detect a specific component in a sample stream, the sample must be composed of the component of interest and one other gas (or specific, and constant, mixture of gases) in order for the measured heat-transfer differences to be nonambiguous.

If, on the other hand, the user is primarily interested in the purity of a process stream, and does not require specific identification of the impurity, the analyzer can be used on more complex mixtures.

2.3 Electronics and Signal Processing

The Model 2010B Thermal Conductivity Analyzer uses an 8031 microcontroller, Central Processing Unit—(CPU) with 32 kB of RAM and 128 kB of ROM to control all signal processing, input/output, and display functions for the analyzer. System power is supplied from a universal power supply module designed to be compatible with any international power source. (See *Major Internal Components* in chapter 5 *Maintenance* for the location of the power supply and the main electronic PC boards.)

The signal processing electronics including the microprocessor, analog to digital, and digital to analog converters are located on the Motherboard at the bottom of the case. The Preamplifier board is mounted on top of the Motherboard as shown in the figure 5.4. These boards are accessible after

removing the back panel. Figure 2-2 is a block diagram of the Analyzer electronics.

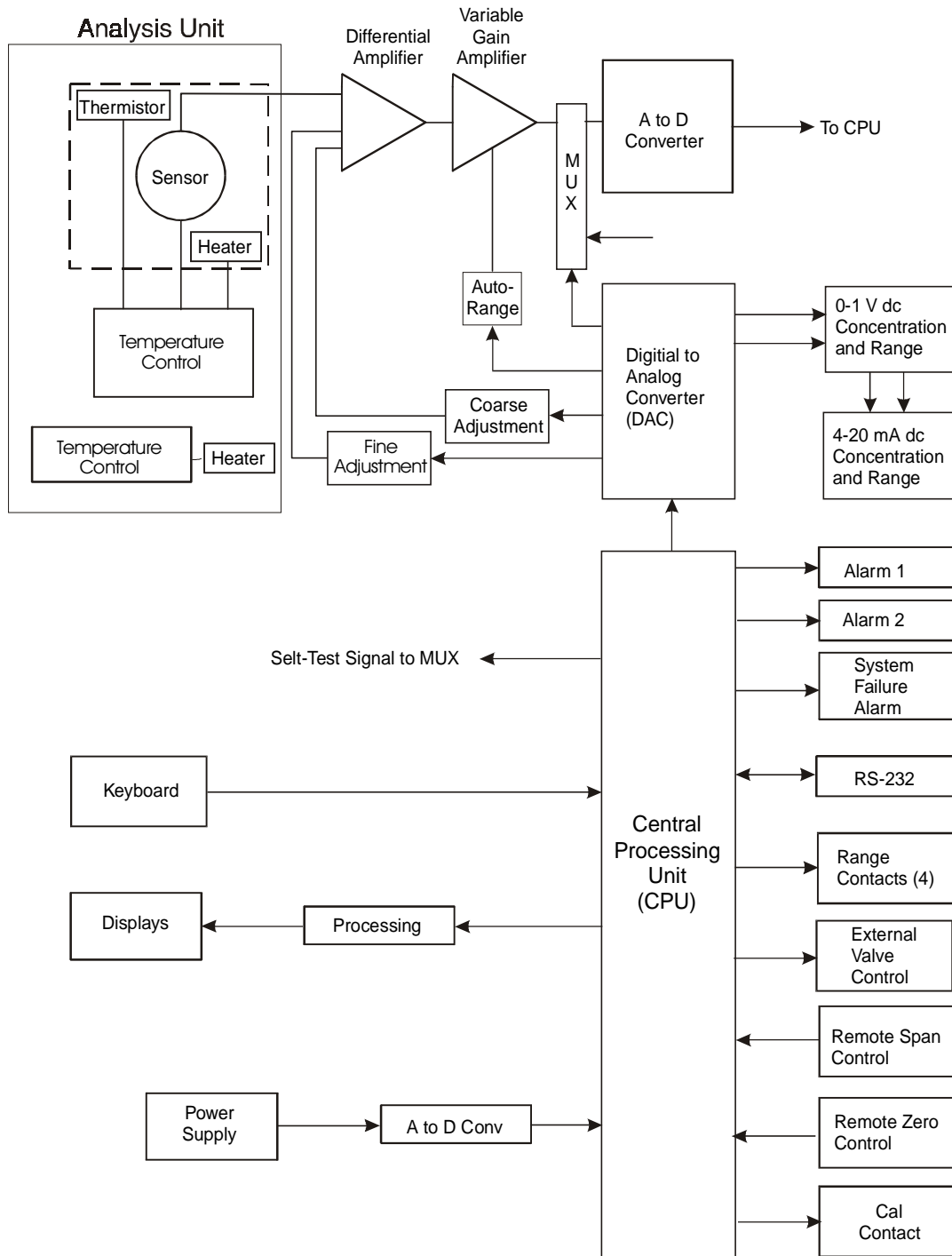

Figure 2-2: Block Diagram of the Model 2010B Electronics

In the presence of dissimilar gases the sensor generates a differential voltage across its output terminals. A differential amplifier converts this signal to a unipolar signal, which is amplified in the second stage, variable gain amplifier, which provides automatic range switching under control of the CPU. The output from the variable gain amplifier is sent to an 18 bit analog to digital converter.

The digital concentration signal along with input from the Gas Selector Panel is processed by the CPU and passed on to the 12-bit DAC, which outputs 0-1 V dc Concentration and Range ID signals. An voltage-to-current converter provides 4-20 mA dc concentration signal and range ID outputs.

The CPU also provides appropriate control signals to the Displays, Alarms, and External Valve Controls, and accepts digital inputs for external Remote Zero and Remote Span commands. It monitors the power supply through an analog to digital converter as part of the data for the system failure alarm.

The RS-232 port provides two-way serial digital communications to and from the CPU. These, and all of the above electrical interface signals are described in detail in chapter 3 *Installation*.

2.4. Temperature Control

For accurate analysis the sensor of this instrument is temperature controlled to 50°C.

The Temperature Control keeps the temperature of the measuring cell regulated to within 0.1 degree C. A thermistor is used to measure the temperature, and a zero-crossing switch regulates the power in a cartridge-type heater. The result is a sensor output signal that is temperature independent.

A second temperature control system is used to maintain the Analysis Unit internal temperature at 22°C minimum.

Installation

Installation of the Model 2010B Analyzer includes:

1. Unpacking
2. Mounting
3. Gas connections
4. Electrical connections
5. Testing the system.

3.1 Unpacking the Analyzer

The analyzer is shipped ready to install and prepared for operation. Carefully unpack the analyzer and inspect it for damage. Immediately report any damage to the shipping agent.

3.2 Mounting the Control Unit

The Model 2010B Control Unit is designed for bulkhead mounting in general purpose area, NOT for hazardous environments of any type. The Control Unit is for indoor/outdoor use.

Figure 3-1 is an illustration of the 2010B standard front panel and mounting bezel. There are four mounting holes—one in each corner of the rigid frame. See the outline drawing, at the back of this manual for overall dimensions.

All operator controls are mounted on the inner control panel, which is hinged on the left edge and doubles as a door to provide access to the internal components of the instrument. The door will swing open when the button of the latch is pressed all the way in with a narrow gauge tool (less than 0.18 inch wide), such as a small hex wrench or screwdriver. Allow clearance for the door to open in a 90-degree arc of radius 11.75 inches. See Figure 3-2.

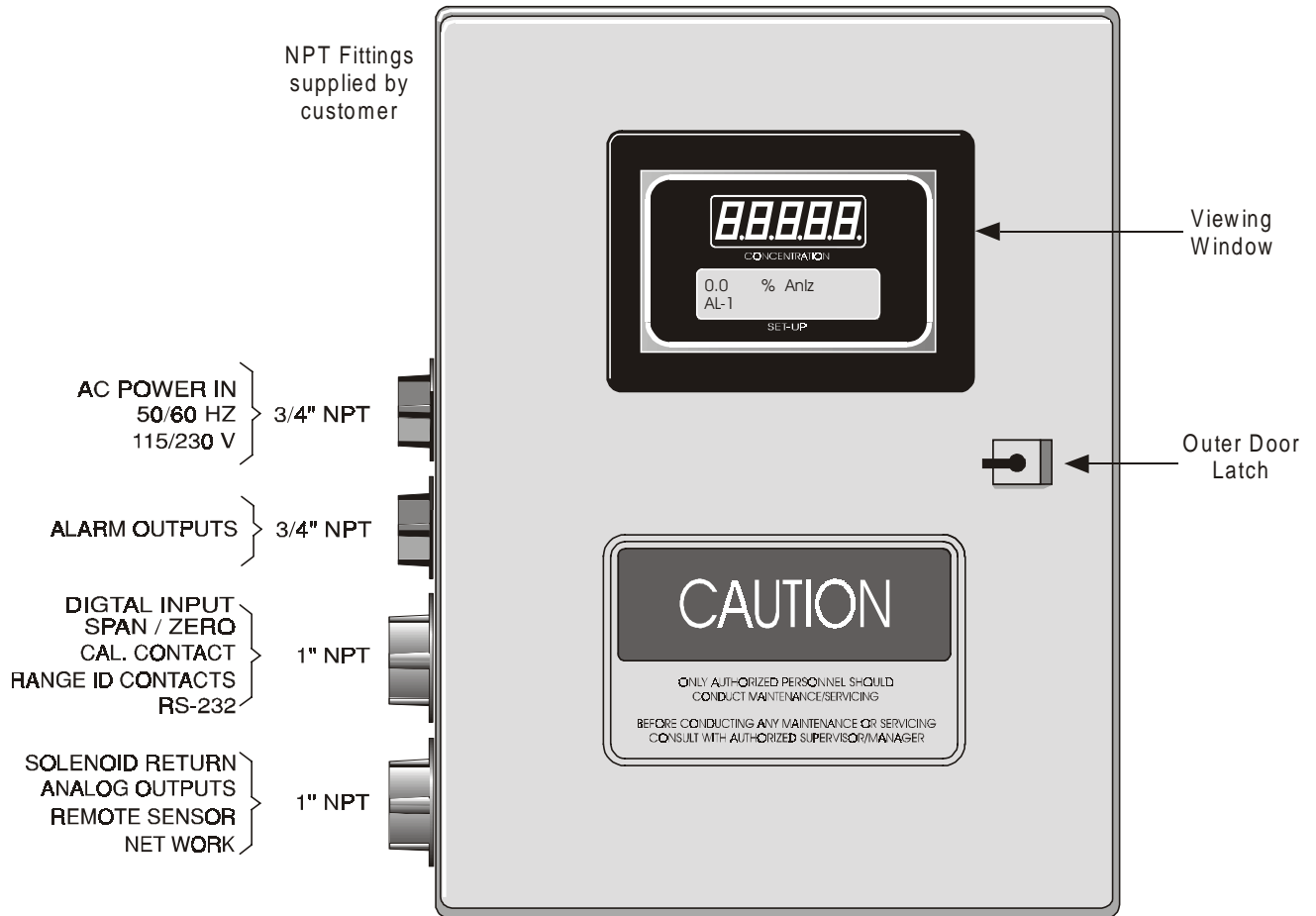

Figure 3-1: Front Panel of the Model 2010B Control Unit

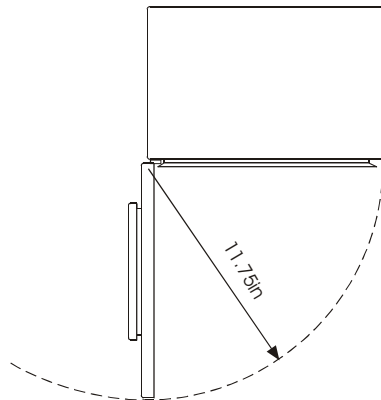

Figure 3-2: Required Front Door Clearance

3.3 Electrical Connections (Rear Panel)

Figure 3-3 shows the Model 2010B Electrical Connector Panel. There are terminal blocks for connecting power, communications, and both digital and analog concentration outputs.

For safe connections, ensure that no uninsulated wire extends outside of the connectors they are attached to. Stripped wire ends must insert completely into terminal blocks. No uninsulated wiring should be able to come in contact with fingers, tools or clothing during normal operation.

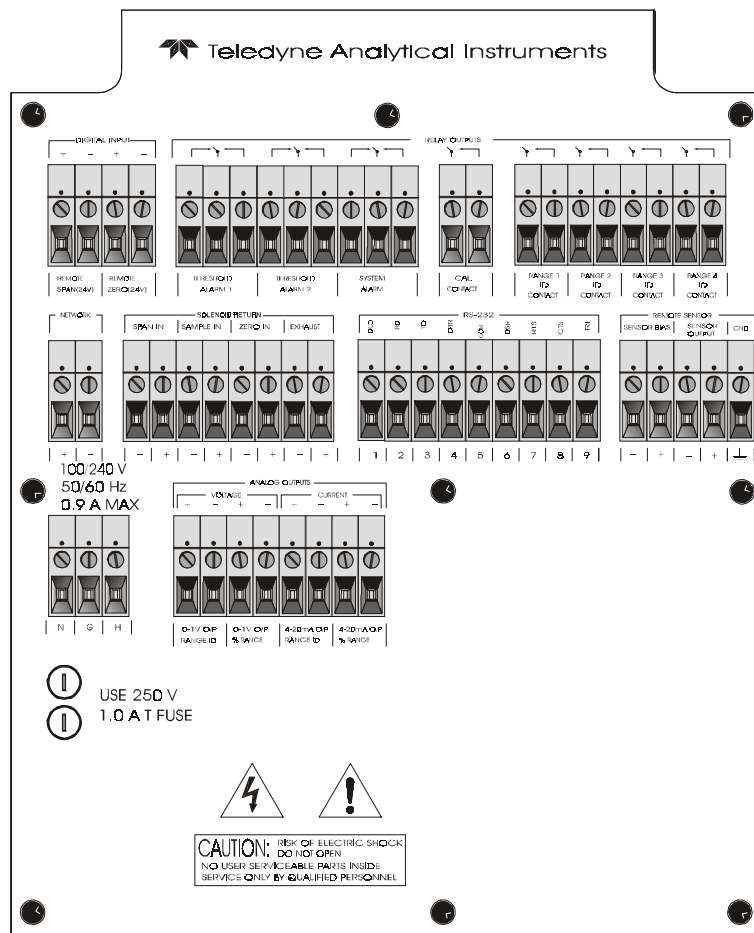

Figure 3-3: Rear Panel of the Model 2010B

3.3.1 Primary Input Power

The power terminal block and fuse receptacles are located in the same rear panel assembly.

DANGER: *POWER IS APPLIED TO THE INSTRUMENT'S CIRCUITRY AS LONG AS THE INSTRUMENT IS CONNECTED TO THE POWER SOURCE. THE RED I/O SWITCH ON THE FRONT PANEL IS FOR SWITCHING POWER ON OR OFF TO THE DISPLAYS AND OUTPUTS ONLY.*



NOTE: *AC POWER MAY BE PRESENT ON THE RELAY CONTACTS WHEN THE POWER CORD IS REMOVED!*



The Control Unit is universal power 100-240V, 50-60 Hz. The Analysis Unit requires 110 or 220 VAC and is selectable via switch located inside the explosion-proof enclosure.

3.3.2 Fuse Installation

The fuse receptacles accepts European size fuses only (5x20mm). Both sides of the line are fused. If the European size fuses are selected, both sides at the line will be fused. Be sure to install the proper fuse as part of installation. (See *Fuse Replacement* in chapter 5, *maintenance*.)

3.3.3 Analog Outputs

There are four DC output signal connectors with spring terminals on the panel. There are two wires per output with the polarity noted. See Figure 3-4. The outputs are:

- 0–1 V dc % of Range: Voltage rises linearly with increasing concentration, from 0 V at 0 concentration to 1 V at full scale. (Full scale = 100% of programmable range.)
- 0–1 V dc Range ID: 0.25 V = Range 1, 0.5 V = Range 2, 0.75 V = Range 3, 1 V = Cal Range.
- 4–20 mA dc % Range: Current rises linearly with concentration, from 4 mA at 0 concentration to 20 mA at full scale. (Full scale = 100% of programmable range.)
- 4–20 mA dc Range ID: 8 mA = Range 1, 12 mA = Range 2, 16 mA = Range 3, 20 mA = Range 4.

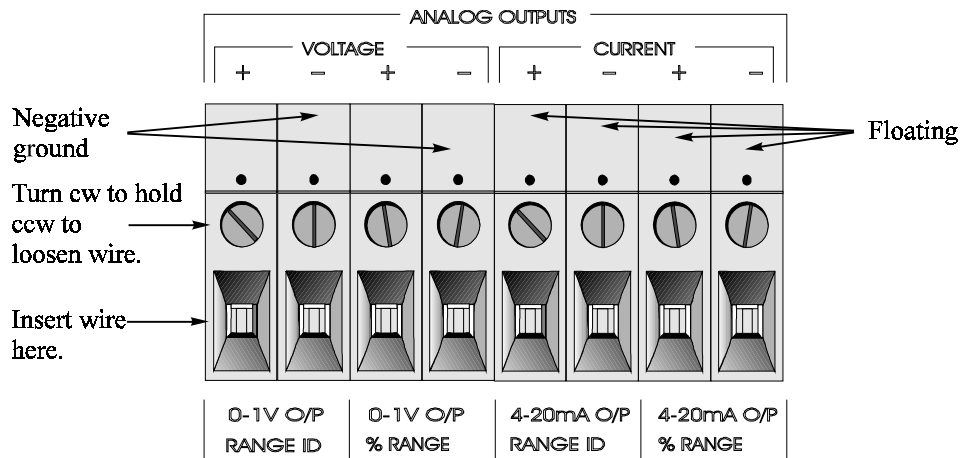

Figure 3-4: Analog Output Connections

Examples:

The analog output signal has a voltage which depends on gas concentration **relative** to the full scale of the range. To relate the signal output to the actual concentration, it is necessary to know what range the instrument is currently on, especially when the analyzer is in the autoranging mode.

The signal output for concentration is linear over the currently selected analysis range. For example, if the analyzer is set on a range that was defined as 0–10 % hydrogen, then the output would be as shown in Table 3-1.

Table 3-1: Analog Concentration Output—Example

Percent Hydrogen	Voltage Signal Output (V dc)	Current Signal Output (mA dc)
0	0.0	4.0
1	0.1	5.6
2	0.2	7.2
3	0.3	8.8
4	0.4	10.4
5	0.5	12.0
6	0.6	13.6
7	0.7	15.2
8	0.8	16.8
9	0.9	18.4
10	1.0	20.0

(Continued)

To provide an indication of the range, the Range ID analog output terminals are used. They generate a steady preset voltage (or current when using the current outputs) to represent a particular range. Table 3-2 gives the range ID output for each analysis range.

Table 3-2: Analog Range ID Output—Example

Range	Voltage (V)	Current (mA)	Application
Range 1	0.25	8	0-1 % H ₂ in N ₂
Range 2	0.50	12	0-10 % H ₂ in N ₂
Range 3	0.75	16	0-1 % H ₂ in Air
Range 4 (Cal)	1.00	20	0-1 % H ₂ in N ₂

3.3.4 Alarm Relays

The three alarm-circuit connectors are spring terminals for making connections to internal alarm relay contacts. Each provides a set of Form C contacts for each type of alarm. Each has both normally open and normally closed contact connections. The contact connections are indicated by diagrams on the rear panel. They are capable of switching up to 3 amperes at 250 V ac into a resistive load. See Figure 3-5. The connectors are:

- Threshold Alarm 1:
- Can be configured as high (actuates when concentration is above threshold), or low (actuates when concentration is below threshold).
 - Can be configured as fail-safe or non-fail-safe.
 - Can be configured as latching or nonlatching.
 - Can be configured out (defeated).
- Threshold Alarm 2:
- Can be configured as high (actuates when concentration is above threshold), or low (actuates when concentration is below threshold).
 - Can be configured as fail-safe or non-fail-safe.
 - Can be configured as latching or nonlatching.
 - Can be configured out (defeated).
- System Alarm:
- Actuates when DC power supplied to circuits is unacceptable in one or more parameters. Permanently configured as fail-safe and latching. Cannot be defeated.
- Actuates when cell can not balance during zero calibration.
- Actuates when span parameter out off its limited parameter.

Actuates when self test fails.

(Reset by pressing **I/O** button to remove power. Then press **I/O** again and any other button EXCEPT **System** to resume.)

Further detail can be found in chapter 4, section 4-5.

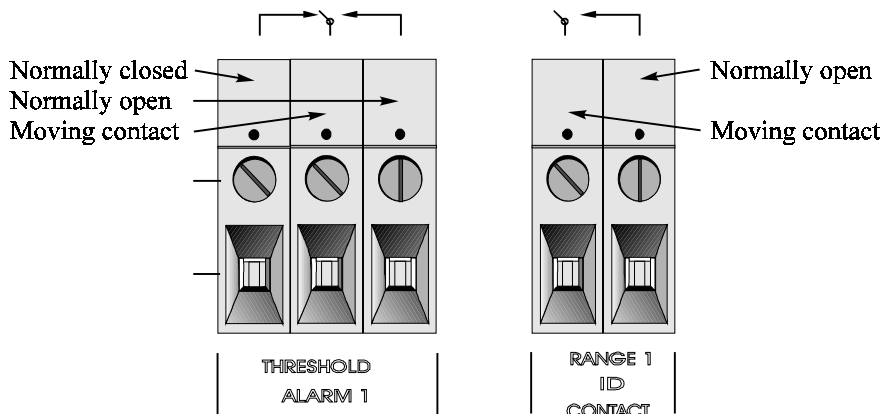

Figure 3-5: Types of Relay Contacts

3.3.5 Digital Remote Cal Inputs

Accept 0 V (off) or 24 V dc (on) inputs for remote control of calibration. (See *Remote Calibration Protocol* below.)

- Zero:** Floating input. 5 to 24 V input across the + and – terminals puts the analyzer into the **Zero** mode. Either side may be grounded at the source of the signal. A synchronous signal must open and close the external gas control valves appropriately. See 3.3.9 *Remote Probe Connector*. (With the –C option, the internal valves operate automatically.)
- Span:** Floating input. 5 to 24 V input across the + and – terminals puts the analyzer into the **Span** mode. Either side may be grounded at the source of the signal. A synchronous signal must open and close the external gas control valves appropriately. See 3.3.9 *Remote Probe Connector*. (With the –C option, the internal valves operate automatically.)

Cal Contact: This relay contact is closed while analyzer is spanning and/or zeroing. (See *Remote Calibration Protocol* below.)

Remote Calibration Protocol: To properly time the Digital Remote Cal Inputs to the Model 2010B Analyzer, the customer's controller must monitor the Cal Relay Contact.

When the contact is OPEN, the analyzer is analyzing, the Remote Cal Inputs are being polled, and a zero or span command can be sent.

When the contact is CLOSED, the analyzer is already calibrating. It will ignore your request to calibrate, and it will not remember that request.

Once a zero or span command is sent, and acknowledged (contact closes), release it. If the command is continued until after the zero or span is complete, the calibration will repeat and the Cal Relay Contact (CRC) will close again.

When the contact is closed, the display would display the last reading of the gas concentration value and output signal would output the last reading from the sample gas (SAMPLE and HOLD).

For example:

- 1) Test the CRC. When the CRC is open, Send a zero command until the CRC closes (The CRC will close quickly.)
- 2) When the CRC closes, remove the zero command.
- 3) When CRC opens again, send a span command until the CRC closes. (The CRC will close quickly.)
- 4) When the CRC closes, remove the span command.

When CRC opens again, zero and span are done, and the sample is being analyzed.

Note: The Remote Probe connector (paragraph 3.3.9) provides signals to operate the zero and span gas valves synchronously. However, if you have the -C, -P, or -Q Internal valve option, which includes zero and span gas inputs, the 2010B automatically selects the zero, span and sample gas flow.

3.3.6 Range ID Relays

Four dedicated Range ID relay contacts. For any single application they are assigned to relays in ascending order. For example: if all ranges have the same application, then the lowest range is assigned to the Range 1 ID relay, and the highest range is assigned to the Range 3 ID relay. Range 4 is the Cal Range ID relay.

3.3.7 Network I/O

A serial digital input/output for local network protocol. At this printing, this port is not yet functional. It is to be used in future versions of the instrument.

3.3.8 RS-232 Port

The digital signal output is a standard RS-232 serial communications port used to connect the analyzer to a computer, terminal, or other digital device. It requires a standard 9-pin D connector.

Output: The data output is status information, in digital form, updated every two seconds. Status is reported in the following order:

- The concentration in ppm or percent
- The range in use (01 = Range 1, 02 = Range 2, 03 = Range 3, CAL = Range 4)
- The scale of the range (0-100 %, etc)
- Which alarms—if any—are disabled (AL-x DISABLED)
- Which alarms—if any—are tripped (AL-x ON).

Each status output is followed by a carriage return and line feed.

Input: The input functions using RS-232 that have been implemented to date are described in Table 3-3.

Table 3-3: Commands via RS-232 Input

Command	Description
as<enter>	Immediately starts an autospan.
az<enter>	Immediately starts an autozero.
rp<enter>	Allows reprogramming of the APPLICATION (gas use) and ALGORITHM (linearization) <i>System</i> functions.
st<enter>	Toggling input. Stops/Starts any status message output from the RS-232, until st<enter> is sent again.
rm1<enter>	Range manual 1
rm2<enter>	Range manual 2
rm3<enter>	Range manual 3
rm4<enter>	Range manual CAL
ra<enter>	Range auto

Implementation: The RS-232 protocol allows some flexibility in its implementation. Table 3-4 lists certain RS-232 values that are required by the Model 2010B implementation.

Table 3-4: Required RS-232 Options

Parameter	Setting
Baud	2400
Byte	8 bits
Parity	none
Stop Bits	1
Message Interval	2 seconds

3.3.9 Remote Probe Connector

The 2010B is a single-split configuration analyzer, the Remote Probe connector is used to interface the Analysis Unit. See Figure 3-6.

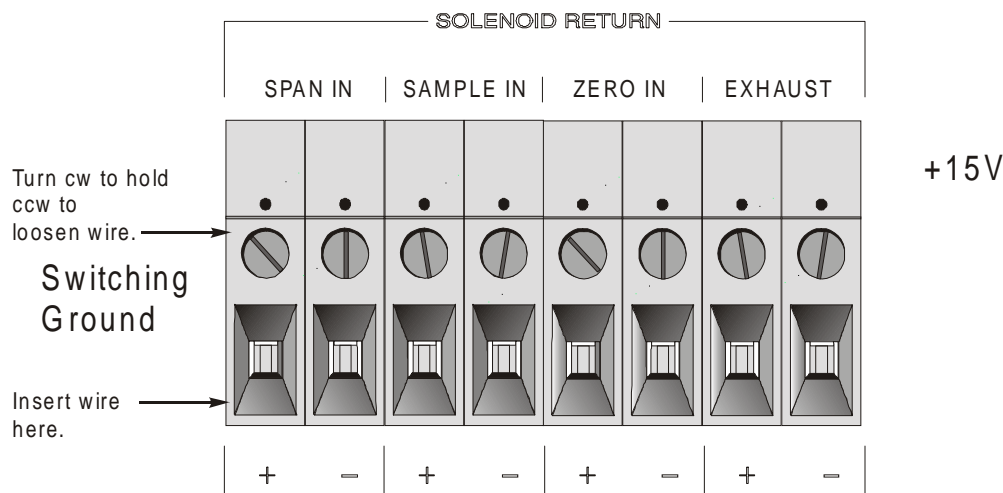

Figure 3-6: Remote Probe Connector Pinouts

The voltage from these outputs is nominally 0 V for the OFF and 15 V dc for the ON conditions. The maximum combined current that can be pulled from these output lines is 100 mA. (If two lines are ON at the same time, each must be limited to 50 mA, etc.) If more current and/or a different voltage is required, use a relay, power amplifier, or other matching circuitry to provide the actual driving current.

In addition, each individual line has a series FET with a nominal ON resistance of 5 ohms (9 ohms worst case). This could limit the obtainable voltage, depending on the load impedance applied. See Figure 3-7.

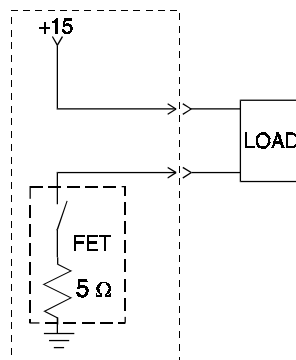

Figure 3-7: FET Series Resistance

3.4 Testing the System

Before plugging the instrument into the power source:

- Check the integrity and accuracy of the gas connections. Make sure there are no leaks.
- Check the integrity and accuracy of the electrical connections. Make sure there are no exposed conductors
- Check that the pressure and flow of all gases are within the recommended levels, and appropriate for your application.

Power up the system, and test it by performing the following operations:

1. Repeat the Self-Diagnostic Test as described in chapter 4, section 4.3.5.

3.5 Warm Up at Power Up

Every time the unit is turned on, the instrument stays with the introduction screen for thirty minutes. This is to allow the cell to come up to temperature (50°C). The only way to bypass this warm up period is by pressing any key once, such as the *Enter* key.

The instrument warms up for half an hour so that it will not receive a remote calibration signal, send false readings to a monitor system, or, again, be calibrated by an untrained operator while the cell is cold.

NOTE: There is no feedback on whether the working temperature has been achieved by cell to the software. If instrument power is interrupted for only a brief time, the instrument will wait thirty minutes again. Press the ENTER key to bypass self-diagnostic mode.

Operation

4.1 Introduction

Although the Model 2010B is usually programmed to your application at the factory, it can be further configured at the operator level, or even, **cautiously**, reprogrammed. Depending on the specifics of the application, this might include all or a subset of the following procedures:

- Setting system parameters:
 - Establish a security password, if desired, requiring Operator to log in.
 - Establish and start an automatic calibration cycle, if desired.
- Routine Operation:
 - Calibrate the instrument.
 - Choose autoranging or select a fixed range of analysis.
 - Set alarm setpoints, and modes of alarm operation (latching, fail-safe, etc).
- Program/Reprogram the analyzer:
 - Define new applications.
 - Linearize your ranges.

If you choose not to use password protection, the default password is automatically displayed on the password screen when you start up, and you simply press *Enter* for access to all functions of the analyzer.

4.2 Using the Data Entry and Function Buttons

Data Entry Buttons: The <> buttons select options from the menu currently being displayed on the VFD screen. The selected option blinks.

When the selected option includes a modifiable item, the Δ ∇ arrow buttons can be used to increment or decrement that modifiable item.

The **Enter** button is used to accept any new entries on the VFD screen. The **Escape** button is used to abort any new entries on the VFD screen that are not yet accepted by use of the **Enter** button.

Figure 4-1 shows the hierarchy of functions available to the operator via the function buttons. The six function buttons on the analyzer are:

- **Analyze.** This is the normal operating mode. The analyzer monitors the thermal conductivity of the sample, displays the percent or parts-per-million of target gas or contamination, and warns of any alarm conditions.
- **System.** The system function consists of nine subfunctions.

Four of these are for ordinary setup and operation:

- Setup an Auto-Cal
- Assign Passwords
- Log out to secure system
- Initiate a Self-Test

Three of the subfunctions do auxiliary tasks:

- Checking model and software version
- Display more subfunctions

Two of these are for programming/reprogramming the analyzer:

- Define gas applications and ranges (Refer to programming section, or contact factory.)
- Use the Curve Algorithm to linearize output. (Refer to programming section, or contact factory.)
- **Zero.** Used to set up a zero calibration.
- **Span.** Used to set up a span calibration.
- **Alarms.** Used to set the alarm setpoints and determine whether each alarm will be active or defeated, HI or LO acting, latching, and/or fail-safe.
- **Range.** Used to set up three analysis ranges that can be switched automatically with autoranging or used as individual fixed ranges.

Any function can be selected at any time by pressing the appropriate button (unless password restrictions apply). The order as presented in this manual is appropriate for an initial setup.

Each of these functions is described in greater detail in the following procedures. The VFD screen text that accompanies each operation is reproduced, at the appropriate point in the procedure, in a Monospaced type style. Push-button names are printed in *Oblique* type.

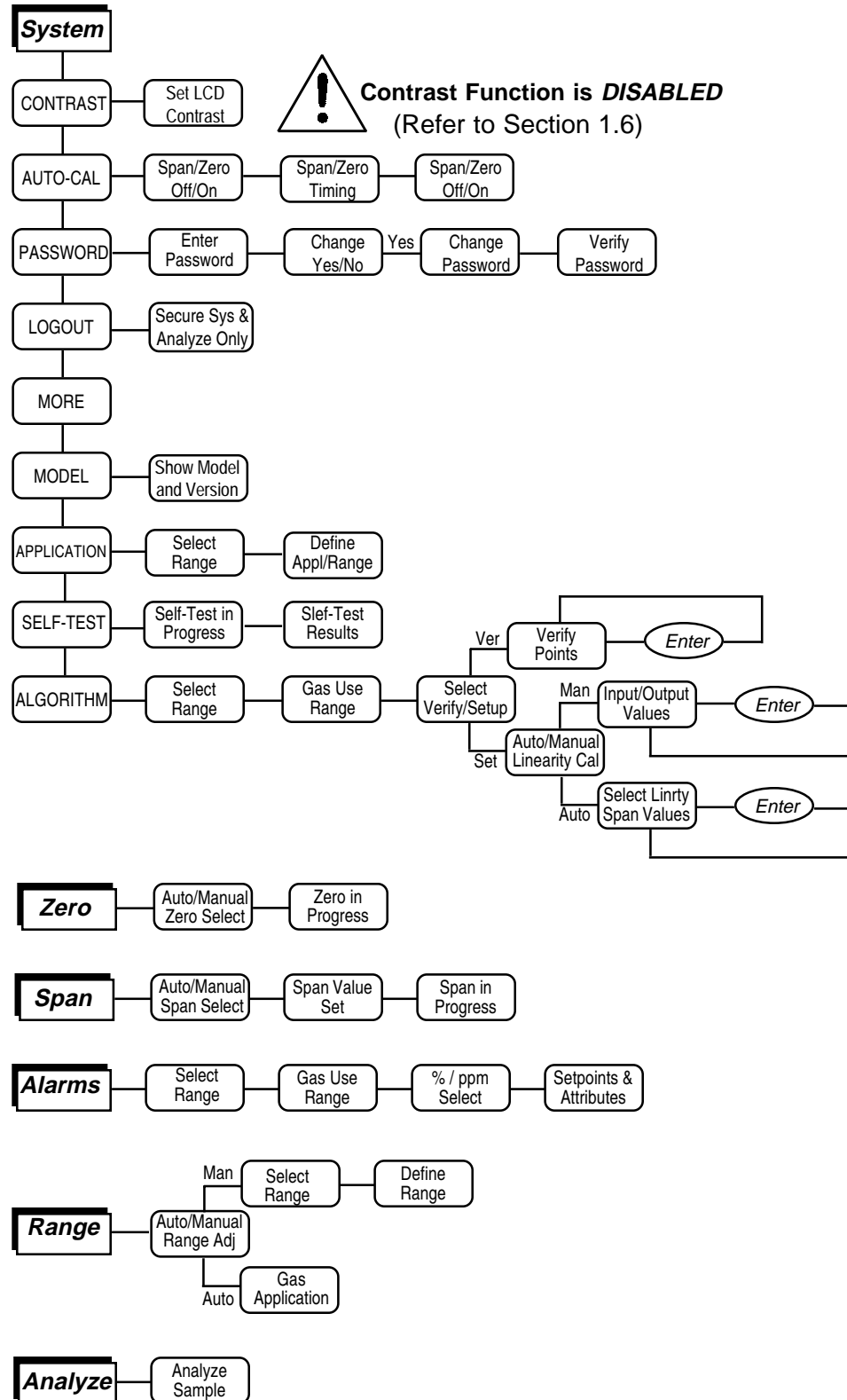

Figure 4-1: Hierarchy of Functions and Subfunctions

4.3 The *System* Function

The subfunctions of the *System* function are described below. Specific procedures for their use follow the descriptions:

- **AUTO-CAL:** Used to define an automatic calibration sequence and/or start an AUTO-CAL.
- **PWD:** Security can be established by choosing a 3 digit password (PWD) from the standard ASCII character set. Once a unique password is assigned and activated, the operator **MUST** enter the **UNIQUE** password to gain access to setup functions which alter the instrument's operation.
- **LOGOUT:** Logging out prevents an unauthorized tampering with analyzer settings.
- **MORE:** Select and enter **MORE** to get a new screen with additional subfunctions listed.
- **MODEL:** Displays Manufacturer, Model, and Software Version of instrument.
- **APPLICATION:** A restricted function, not generally accessed by the end user. Used to define up to three analysis ranges and a calibration range (including impurity, background, low end of range, high end of range, and % or ppm units).
- **SELF-TEST:** The instrument performs a self-diagnostic test to check the integrity of the power supply, output boards, sensor cell, and preamplifiers.
- **ALGORITHM:** A restricted function, not generally accessed by the end user. Used to linearize the output for the range of interest.

4.3.1 Setting the Display

Contrast Function is **DISABLED**
(Refer to Section 1.6)



If you cannot read anything on the VFD after first powering up:

1. Observe LED readout.
 - a. If LED meter reads **8.8.8.8.8.**, go to step 3.
 - b. If LED meter displays anything else, go to step 2.
2. Press **//O** button twice to turn Analyzer OFF and ON again. LED meter should now read **8.8.8.8.8.** Go to step 3.

4.3.2 Setting up an AUTO-CAL

When proper automatic valving is connected (see chapter 3, *installation*), the Analyzer can cycle itself through a sequence of steps that automatically zero and span the instrument.

Note: Before setting up an AUTO-CAL, be sure you understand the *Zero* and *Span* functions as described in section 4.4, and follow the precautions given there.

Note: If you require highly accurate AUTO-CAL timing, use external AUTO-CAL control where possible. The internal clock in the Model 2010B is accurate to 2-3 %. Accordingly, internally scheduled calibrations can vary 2-3 % per day.

Note: If all your ranges are for the same gas application, then AUTO-CAL will calibrate whichever range you are in at the scheduled time for automatic calibration.

Note: If your ranges are configured for different applications, then AUTO-CAL will calibrate all of the ranges simultaneously (by calibrating the Cal Range).

To setup an Auto-Cal cycle:

Choose *System* from the Function buttons. The VFD will display five subfunctions.



Contrast Function is **DISABLED**
(Refer to Section 1.6)

CONTRAST AUTO-CAL
PWD LOGOUT MORE

Use <> arrows to blink AUTO-CAL, and press *Enter*. A new screen for ZERO/SPAN set appears.

```
ZERO in  0d 0h off
SPAN in  0d 0h off
```

Press <> arrows to blink ZERO (or SPAN), then press *Enter* again. (You won't be able to set OFF to ON if a zero interval is entered.) A Span Every ... (or Zero Every ...) screen appears.

```
Zero schedule: OFF
Day: 0d Hour: 0h
```

Use $\Delta\nabla$ arrows to set an interval value, then use <> arrows to move to the start-time value. Use $\Delta\nabla$ arrows to set a start-time value.

To turn ON the SPAN and/or ZERO cycles (to activate AUTO-CAL): Press *System* again, choose AUTO-CAL, and press *Enter* again. When the ZERO/SPAN values screen appears, use the <> arrows to blink the ZERO (or SPAN) and press *Enter* to go to the next screen. Use <> to select OFF/ON field. Use $\Delta\nabla$ arrows to set the OFF/ON field to ON. You can now turn these fields ON because there is a nonzero span interval defined.

4.3.3 Password Protection

Before a unique password is assigned, the system assigns TAl by default. This password will be displayed automatically. The operator just presses the Enter key to be allowed total access to the instrument's features.

If a password is assigned, then setting the following system parameters can be done only after the password is entered: **alarm** setpoints, assigning a new **password, range/application** selections, and **curve algorithm** linearization. (APPLICATION and ALGORITHM are covered in the programming section.) However, the instrument can still be used for analysis or for initiating a self-test without entering the password. To defeat security the password must be changed back to TAl.

NOTE: If you use password security, it is advisable to keep a copy of the password in a separate, safe location.

4.3.3.1 Entering the Password

To install a new password or change a previously installed password, you must key in and *ENTER* the old password first. If the default password is in effect, pressing the *ENTER* button will enter the default TAI password for you.

Press *System* to enter the *System* mode.



Contrast Function is *DISABLED*
(Refer to Section 1.6)

```
CONTRAST  AUTO-CAL
PWD      LOGOUT  MORE
```

Use the <> arrow keys to scroll the blinking over to PWD, and press *Enter* to select the password function. Either the default TAI password or AAA place holders for an existing password will appear on screen depending on whether or not a password has been previously installed.

```
Enter password:
  T A I
```

or

```
Enter password:
  A A A
```

The screen prompts you to enter the current password. If you are not using password protection, press *Enter* to accept TAI as the default password. If a password has been previously installed, enter the password using the <> arrow keys to scroll back and forth between letters, and the $\Delta\nabla$ arrow keys to change the letters to the proper password. Press *Enter* to enter the password.

In a few seconds, you will be given the opportunity to change this password or keep it and go on.

```
Change Password?
<ENT>=Yes  <ESC>=No
```

Press *Escape* to move on, or proceed as in *Changing the Password*, below.

4.3.3.2 Installing or Changing the Password

If you want to install a password, or change an existing password, proceed as above in *Entering the Password*. When you are given the opportunity to change the password:

```
Change Password?
<ENT>=Yes  <ESC>=No
```

Press *Enter* to change the password (either the default TAI or the previously assigned password), or press *Escape* to keep the existing password and move on.

If you chose *Enter* to change the password, the password assignment screen appears.

Select new password
T A I

Enter the password using the <> arrow keys to move back and forth between the existing password letters, and the $\Delta\nabla$ arrow keys to change the letters to the new password. The full set of 94 characters available for password use are shown in the table below.

Characters Available for Password Definition:

A	B	C	D	E	F	G	H	I	J
K	L	M	N	O	P	Q	R	S	T
U	V	W	X	Y	Z	[¥]	^
_	`	a	b	c	d	e	f	g	h
ı	j	k	l	m	n	o	p	q	r
s	t	u	v	w	x	y	z	{	
}	→	!	"	#	\$	%	&	'	(
)	*	+	,	-	.	/	0	1	2
3	4	5	6	7	8	9	:	;	<
=	>	?	@						

When you have finished typing the new password, press *Enter*. A verification screen appears. The screen will prompt you to retype your password for verification.

Enter PWD To Verify:
A A A

Use the arrow keys to retype your password and press *Enter* when finished. Your password will be stored in the microprocessor and the system will immediately switch to the *Analyze* screen, and you now have access to all instrument functions.

If all alarms are defeated, the *Analyze* screen appears as:

1.95 % H2 in N2
nR1: 0 – 10 Anlz

If an alarm is tripped, the second line will change to show which alarm it is:

1.95 % H2 in N2
A L-1

NOTE: If you log off the system using the LOGOUT function in the system menu, you will now be required to re-enter the password to gain access to Alarm, and Range functions.

4.3.4 Logging Out

The LOGOUT function provides a convenient means of leaving the analyzer in a password protected mode without having to shut the instrument off. By entering LOGOUT, you effectively log off the instrument leaving the system protected against use until the password is reentered. To log out, press the *System* button to enter the *System* function.



Contrast Function is *DISABLED*
(Refer to Section 1.6)

```

CONTRAST    AUTO-CAL
PWD  LOGOUT  MORE
  
```

Use the < > arrow keys to position the blinking over the LOGOUT function, and press *Enter* to Log out. The screen will display the message:

```

Protected until
password entered
  
```

4.3.5 System Self-Diagnostic Test

The Model 2010B has a built-in self-diagnostic testing routine. Pre-programmed signals are sent through the power supply, output board, preamp board and sensor circuit. The return signal is analyzed, and at the end of the test the status of each function is displayed on the screen, either as OK or as a number between 1 and 1024. (See *System Self Diagnostic Test* in chapter 5 for number code.) If any of the functions fails, the System Alarm is tripped.

Note: The sensor will always show failed unless identical gas is present in both channels at the time of the SELF-TEST.

The self diagnostics are run automatically by the analyzer whenever the instrument is turned on, but the test can also be run by the operator at will. To initiate a self diagnostic test during operation:

Press the *System* button to start the *System* function.



Contrast Function is *DISABLED*
(Refer to Section 1.6)

```

CONTRAST    AUTO-CAL
PWD  LOGOUT  MORE
  
```

Use the < > arrow keys to blink MORE, then press *Enter*.

```

MODEL APPLICATION
SELF-TEST  ALGORITHM
  
```

Use the < > arrow keys again to move the blinking to the SELF-TEST and press *Enter*. The screen will follow the running of the diagnostic.

```

RUNNING DIAGNOSTIC
Testing Preamp – Cell

```

When the testing is complete, the results are displayed.

```

Power: OK Analog: OK
Cell: 2 Preamp: 3

```

The module is functioning properly if it is followed by OK. A number indicates a problem in a specific area of the instrument. Refer to Chapter 5 *Maintenance and Troubleshooting* for number-code information. The results screen alternates for a time with:

```

Press Any Key
To Continue...

```

Then the analyzer returns to the initial System screen.

4.3.6 The Model Screen

Move the < > arrow key to MORE and press *Enter*. With MODEL blinking, press *Enter*. The screen displays the manufacturer, model, and software version information.

4.3.7 Checking Linearity with ALGORITHM

From the *System* Function screen, select ALGORITHM, and press *Enter*.

```

sel rng to set algo:
-> 01 02 03 <-

```

Use the < > keys to select the range: 01, 02, or 03. Then press *Enter*.

```

Gas Use: H2 – N2
Range: 0 – 10%

```

Press Enter again.

```

Algorithm setup:
VERIFY SET UP

```

Select and *Enter* VERIFY to check whether the linearization has been accomplished satisfactorily.

```

Dpt INPUT OUTPUT
0 0.00 0.00

```

The leftmost digit (under Dpt) is the number of the data point being monitored. Use the $\Delta \nabla$ keys to select the successive points.

The INPUT value is the input to the linearizer. It is the simulated output of the analyzer. **You do not need to actually flow gas.**

The OUTPUT value is the output of the linearizer. It should be the ACTUAL concentration of the span gas being simulated.

If the OUTPUT value shown is not correct, the linearization must be corrected. Press *ESCAPE* to return to the previous screen. Select and Enter SET UP to Calibration Mode screen.

Select algorithm
mode : AUTO

There are two ways to linearize: AUTO and MANUAL: The auto mode requires as many calibration gases as there will be correction points along the curve. The user decides on the number of points, based on the precision required.

The manual mode only requires entering the values for each correction point into the microprocessor via the front panel buttons. Again, the number of points required is determined by the user.

4.4 The Zero and Span Functions

(1) The Model 2010B can have as many as three analysis ranges plus a special calibration range (Cal Range); and the analysis ranges, if more than one, may be programmed for separate or identical gas applications.

(2) If all ranges are for the same application, then you will not need the Cal Range. Calibrating any one of the ranges will automatically calibrate the others.

(3) If: a) each range is programmed for a different gas application, b) your sensor calibration has drifted less than 10 %, and c) your Cal Range was calibrated along with your other ranges when last calibrated, then you can use the Cal Range to calibrate all applications ranges at once.

If your Model 2010B analyzer fits the paragraph (3) description, above, use the Cal Range. If your analyzer has drifted more than 10 %, calibrate each range individually.

CAUTION: Always allow 4-5 hours warm-up time before calibrating, if your analyzer has been disconnected from its power source. This does not apply if the analyzer was plugged in but was in STANDBY.

The analyzer is calibrated using reference, zero, and span gases. Gas requirements are covered in detail in chapter 3, section 3.4 *Gas Connections*. Check that calibration gases are connected to the analyzer according to the instructions in section 3.4, observing all the prescribed precautions.

Note: Shut off the gas pressure before connecting it to the analyzer, and be sure to limit pressure to 40 psig or less when turning it back on.

Readjust the gas pressure into the analyzer until the flowrate through the sensor settles between 50 to 200 cc/min (approximately 0.1 to 0.4 scfh).

Note: Always keep the zero calibration gases flow as close to the flowrate of sample gas as possible

4.4.1 Zero Cal

The *Zero* button on the front panel is used to enter the zero calibration function. Zero calibration can be performed in either the automatic or manual mode.

CAUTION: *If you are zeroing the Cal Range by itself (multiple application analyzers only), use manual mode zeroing.*



If you want to calibrate ALL of the ranges at once (multiple application analyzers only), use auto mode zeroing in the Cal Range.

Make sure the zero gas is flowing to the instrument. If you get a CELL CANNOT BE BALANCED message while zeroing skip to section 4.4.1.3.

4.4.1.1 Auto Mode Zeroing

Observe the precautions in sections 4.4 and 4.4.1, above. Press *Zero* to enter the zero function mode. The screen allows you to select whether the zero calibration is to be performed automatically or manually. Use the $\Delta\nabla$ arrow keys to toggle between AUTO and MAN zero settling. Stop when AUTO appears, blinking, on the display.

Select zero
mode: AUTO

Press *Enter* to begin zeroing.

#####.## % H2 - N2
Slope=#.### C-Zero

The beginning zero level is shown in the upper left corner of the display. As the zero reading settles, the screen displays and updates information on Slope= in percent/second (unless the Slope starts within the acceptable zero range and does not need to settle further). The system first does a course zero, shown in the lower right corner of the screen as C–Zero, for 3 min, and then does a fine zero, and displays F–Zero, for 3 min.

Then, and whenever Slope is less than 0.01 for at least 3 min, instead of Slope you will see a countdown: 9 Left, 8 Left, and so fourth. These are software steps in the zeroing process that the system must complete, AFTER settling, before it can go back to *Analyze*. Software zero is indicated by S–Zero in the lower right corner.

```
#####.## % H2 – N2
4 Left=#.### S–Zero
```

The zeroing process will automatically conclude when the output is within the acceptable range for a good zero. Then the analyzer automatically returns to the *Analyze* mode.

4.4.1.2 Manual Mode Zeroing

Press *Zero* to enter the *Zero* function. The screen that appears allows you to select between automatic or manual zero calibration. Use the ΔV keys to toggle between AUTO and MAN zero settling. Stop when MANUAL appears, blinking, on the display.

```
Select zero
mode:  MANUAL
```

Press *Enter* to begin the zero calibration. After a few seconds the first of three zeroing screens appears. The number in the upper left hand corner is the first-stage zero offset. The microprocessor samples the output at a predetermined rate.

```
#####.## % H2 – N2
Zero adj: 2048 C–Zero
```

The analyzer goes through C–Zero, F–Zero, and S–Zero. During C–Zero and F–Zero, use the ΔV keys to adjust displayed Zero adj: value as close as possible to zero. Then, press *Enter*.

S–Zero starts. During S–Zero, the Microcontroller takes control as in *Auto Mode Zeroing*, above. It calculates the differences between successive samplings and displays the rate of change as Slope= a value in parts per million per second (ppm/s).

####.## % H2 - N2
Slope=#.### S-Zero

Generally, you have a good zero when Slope is less than 0.05 ppm/s for about 30 seconds.

Once zero settling completes, the information is stored in the analyzer's memory, and the instrument automatically returns to the *Analyze* mode.

4.4.1.3 Cell Failure

Cell failure in the 2010B is usually associated with inability to zero the instrument with a reasonable voltage differential across the Wheatstone bridge. If this should ever happen, the 2010B system alarm trips, and the VFD displays a failure message.

Cell cannot be balanced
Check your zero gas

Before replacing the sensor:

- a. Check your zero gas to make sure it is within specifications.
- b. Check for leaks downstream from the sensor, where contamination may be leaking into the system.
- c. Check flowmeter to ensure that the flow is no more than 200SCCM
- d. Check temperature controller board.
- e. Check gas temperature.

If none of the above as indicated, the sensor may need to be replaced. Check warranty, and contact Analytical Instruments Customer Service.

4.4.2 Span Cal

The *Span* button on the front panel is used to span calibrate the analyzer. Span calibration can be performed in either the automatic or manual mode.

CAUTION: If you are spanning the Cal Range by itself (multiple application analyzers only), use manual mode zeroing.

If you want to calibrate ALL of the ranges at once (multiple application analyzers only), use auto mode spanning in the Cal Range.

Make sure the span gas is flowing to the instrument.

4.4.2.1 Auto Mode Spanning

Observe all precautions in sections 4.4 and 4.4.2, above. Press *Span* to enter the span function. The screen that appears allows you to select whether the span calibration is to be performed automatically or manually. Use the $\Delta\nabla$ arrow keys to toggle between AUTO and MAN span settling. Stop when AUTO appears, blinking, on the display.

```
Select span  
mode: AUTO
```

Press *Enter* to move to the next screen.

```
Span Val: 20.00 %  
<ENT> To begin span
```

Use the $\langle \rangle$ arrow keys to toggle between the span concentration value and the units field (%/ppm). Use the $\Delta\nabla$ arrow keys change the value and/or the units, as necessary. When you have set the concentration of the span gas you are using, press *Enter* to begin the Span calibration.

```
#####.##% H2 - N2  
Slope=##### Span
```

The beginning span value is shown in the upper left corner of the display. As the span reading settles, the screen displays and updates information on Slope. Spanning automatically ends when the span output corresponds, within tolerance, to the value of the span gas concentration. Then the instrument automatically returns to the analyze mode.

4.4.2.2 Manual Mode Spanning

Press *Span* to start the *Span* function. The screen that appears allows you to select whether the span calibration is to be performed automatically or manually.

```
Select span  
mode: MANUAL
```

Use the $\Delta\nabla$ keys to toggle between AUTO and MAN span settling. Stop when MAN appears, blinking, on the display. Press *Enter* to move to the next screen.

```
Span Val: 20.00 %  
<ENT> To begin span
```

Use the $\langle \rangle$ arrow keys to toggle between the span concentration value and the units field (%/ppm). Use the $\Delta\nabla$ arrow keys change the value and/or the

units, as necessary. When you have set the concentration of the span gas you are using, press *Enter* to begin the Span calibration.

Press *Enter* to enter the span value into the system and begin the span calibration.

Once the span has begun, the microprocessor samples the output at a predetermined rate. It calculates the difference between successive samplings and displays this difference as Slope on the screen. It takes several seconds for the first Slope value to display. Slope indicates rate of change of the Span reading. It is a sensitive indicator of stability.

```
###.##% H2 - N2
Slope=#.### Span
```

When the Span value displayed on the screen is sufficiently stable, press *Enter*. (Generally, when the Span reading changes by 1 % or less of the range being calibrated for a period of ten minutes it is sufficiently stable.) Once *Enter* is pressed, the Span reading changes to the correct value. The instrument then **automatically** enters the *Analyze* function.

4.5 The Alarms Function

The Model 2010B is equipped with 6 fully adjustable set points concentration with two alarms and a system failure alarm relay. Each alarm relay has a set of form "C" contacts rated for 3 amperes resistive load at 250 V ac. See Figure in Chapter 3, *Installation* and/or the Interconnection Diagram included at the back of this manual for relay terminal connections.

The system failure alarm has a fixed configuration described in chapter 3 *Installation*.

The concentration alarms can be configured from the front panel as either *high* or *low* alarms by the operator. The alarm modes can be set as *latching* or *non-latching*, and either *failsafe* or *non-failsafe*, or, they can be *defeated* altogether. The setpoints for the alarms are also established using this function.

Decide how your alarms should be configured. The choice will depend upon your process. Consider the following four points:

1. Which if any of the alarms are to be high alarms and which if any are to be low alarms?

Setting an alarm as HIGH triggers the alarm when the contaminant concentration rises above the setpoint. Setting an alarm as LOW triggers the alarm when the contaminant concentration falls below the setpoint.

Decide whether you want the alarms to be set as:

- Both high (high and high-high) alarms, or
 - One high and one low alarm, or
 - Both low (low and low-low) alarms.
2. Are either or both of the alarms to be configured as failsafe?
In failsafe mode, the alarm relay de-energizes in an alarm condition. For non-failsafe operation, the relay is energized in an alarm condition. You can set either or both of the concentration alarms to operate in failsafe or non-failsafe mode.
 3. Are either of the alarms to be latching?
In latching mode, once the alarm or alarms trigger, they will remain in the alarm mode even if process conditions revert back to non-alarm conditions. This mode requires an alarm to be recognized before it can be reset. In the non-latching mode, the alarm status will terminate when process conditions revert to non-alarm conditions.
 4. Are either of the alarms to be defeated?
The defeat alarm mode is incorporated into the alarm circuit so that maintenance can be performed under conditions which would normally activate the alarms.
The defeat function can also be used to reset a latched alarm.
(See procedures, below.)

If you are using password protection, you will need to enter your password to access the alarm functions. Follow the instructions in section 4.3.3 to enter your password. Once you have clearance to proceed, enter the *Alarm* function.

Note: If all ranges are for the same application, setting one of them will automatically set the others.

Press the *Alarm* button on the front panel to enter the *Alarm* function. Make sure that 01 is blinking.

```

Sel rng to set alm:
-> 01 02 03  <-

```

Set up the Range 1 alarm by moving the blinking over to 01 using the <> arrow keys. Then press *Enter*. Check the gas application and range limits as displayed on the screen.

```

Gas use: H2 - N2
Range: 0 - 10 %

```

Press enter again to set the alarm setpoints.

```

Sel %/ppm alm to set
AL1-PPM  AL2-PPM

```

Use the $\Delta\nabla$ keys to choose between % or ppm units. Then press *Enter* to move to the next screen.

```
AL1: 1000 ppm HI
Dft:N Fs:N Ltch:N
```

Five parameters can be changed on this screen:

- Value of the alarm setpoint, AL1: #####
- Out-of-range direction, HI or LO
- Defeated? Dft: Y/N (Yes/No)
- Failsafe? Fs: Y/N (Yes/No)
- Latching? Ltch: Y/N (Yes/No).
- To define the setpoint, use the < > arrow keys to move the blinking over to AL1: #####. Then use the $\Delta\nabla$ arrow keys to change the number. Holding down the key speeds up the incrementing or decrementing.
- To set the other parameters use the < > arrow keys to move the blinking over to the desired parameter. Then use the $\Delta\nabla$ arrow keys to change the parameter.
- Once the parameters for alarm 1 have been set, press *Alarms* again, and repeat this procedure for alarm 2 (AL2).
- To reset a latched alarm, go to Dft- and then press either Δ two times or ∇ two times. (Toggle it to Y and then back to N.)

–OR –

Go to Ltch- and then press either Δ two times or ∇ two times. (Toggle it to N and back to Y.)

4.6 The Range Select Function

The *Range* function allows you to manually select the concentration range of analysis (MANUAL), or to select automatic range switching (AUTO).

In the MANUAL screen, you are further allowed to define the high and low (concentration) limits of each Range, and select a single, fixed range to run.

CAUTION: If this is a linearized application, the new range must be within the limits previously programmed using the System function, if linearization is to apply throughout the range. Furthermore, if the limits are too small a part (approx 10 % or less) of the originally linearized range, the linearization will be compromised.

In the AUTO screen, you are further allowed to select which gas application (PREVIOUSLY defined in *System* function) to run.

4.6.1 Manual (Select/Define Range) Screen

The Manual range-switching mode allows you to select a single, fixed analysis range. It then allows you to redefine the upper and lower limits, for the range.

Press *Range* key to start the Range function.

```
Select range
mode:  MANUAL
```

Note: If all three ranges are currently defined for different application gases, then the above screen does not display (because mode must be manual). Instead, the VFD goes directly to the following screen.

If above screen displays, use the $\Delta\nabla$ arrow keys to Select MANUAL, and press *Enter*.

```
Select range to run
-> 01 02 03 CAL<-
```

Use the <> keys to select the range: 01, 02, 03, or CAL. Then press *Enter*.

```
Gas use:  H2 - N2
Range:    0 - 10 %
```

Use the <> keys to toggle between the Range: low-end field and the Range: high-end field. Use the $\Delta\nabla$ keys to change the values of the fields.

Press *Escape* to return to the previous screen to select or define another range.

Press *Enter* to return the to the *Analyze* function.

4.6.2 Auto (Single Application) Screen

Autoranging will automatically set to the application that has at least two range setup with the same gases.

In the autoranging mode, the microprocessor automatically responds to concentration changes by switching ranges for optimum readout sensitivity. If the upper limit of the operating range is reached, the instrument automatically shifts to the next higher range. If the concentration falls to below 85% of full scale of

the next lower range, the instrument switches to the lower range. A corresponding shift in the DC concentration output, and in the range ID outputs, will be noticed.

The autoranging feature can be overridden so that analog output stays on a fixed range regardless of the contaminant concentration detected. If the concentration exceeds the upper limit of the range, the DC output will saturate at 1 V dc (20 mA at the current output).

However, the digital readout and the RS-232 output of the concentration are unaffected by the fixed range. They continue to read beyond the full-scale setting until amplifier saturation is reached. Below amplifier saturation, the overrange readings are accurate UNLESS the application uses linearization over the selected range.

The concentration ranges can be redefined using the *Range* function Manual screen, and the application gases can be redefined using the *System* function, **if** they are not already defined as necessary.

CAUTION: Redefining applications or ranges might require relinearization and/or recalibration.

To setup automatic ranging:

Press *Range* key to start the Range function.

```
Select range  
mode : AUTO
```

Note: If all three ranges are currently defined for different application gases, then the above screen does not display (because mode must be manual).

If above screen displays, use the Δ and ∇ arrow keys to Select AUTO, and press *Enter*.

Press *Escape* to return to the previous Analyze Function.

4.6.3 Precautions

The Model 2010B allows a great deal of flexibility in choosing ranges for automatic range switching. However, there are some pitfalls that are to be avoided.

Ranges that work well together are:

- Ranges that have the same lower limits but upper limits that differ by approximately an order of magnitude
- Ranges whose upper limits coincide with the lower limits of the next higher range
- Ranges where there is a gap between the upper limit of the range and the lower limit of the next higher range.

Range schemes that are to be avoided include:

- Ranges that overlap
- Ranges whose limits are entirely within the span of an adjoining range.

Figure 4-2 illustrates these schemes graphically.

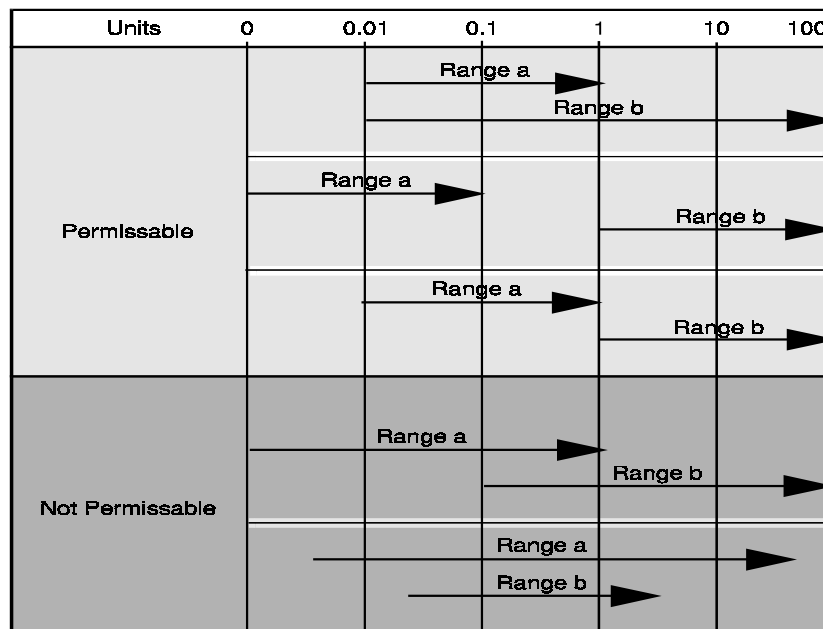

Figure 4-2: Examples of Autoranging Schemes

4.7 The Analyze Function

Normally, all of the functions automatically switch back to the *Analyze* function when they have completed their assigned operations. Pressing the

Escape button in many cases also switches the analyzer back to the *Analyze* function. Alternatively, you can press the *Analyze* button at any time to return to analyzing your sample.

The *Analyze* function screen shows the impurity concentration and the application gases in the first line, and the range in the second line. In the lower right corner, the abbreviation Anlz indicates that the analyzer is in the *Analyze* mode. If there is an * before the Anlz, it indicates that the range is linearized.

```
1.95 % H2 - N2
nR1:Ø-10 *Anlz
```

n indicates noninverting range

i indicates inverting range

If the concentration detected is overrange, the first line of the display blinks continuously.

4.8 Programming

CAUTION: *The programming functions of the Set Range and Curve Algorithm screens are configured at the factory to the users application specification. These functions should only be reprogrammed by trained, qualified personnel.*

To program, you must:

1. Enter the password, if you are using the analyzer's password protection capability.
2. Connect a computer or computer terminal capable of sending an RS-232 signal to the analyzer RS-232 connector. (See chapter 3 *Installation* for details). Send the **rp** command to the analyzer.

OR

For software 1.1.4 or later, turn the instrument off and back on. While on the introduction screen hold the *Analyze* key for at least fifteen seconds. Press the *Enter* key twice to return to the Analyze mode.

3. Press the *System* button to start the *System* function.

```
CONTRAST    AUTO-CAL
PWD         LOGOUT    MORE
```



Contrast Function is DISABLED
(Refer to Section 1.6)

Use the <> arrow keys to blink MORE, then press *Enter*.

MODEL APPLICATION
SELF_TEST ALGORITHM

Now you will be able to select the APPLICATION and ALGORITHM set-up functions.

4.8.1 The Set Range Screen

The Set Range screen allows reprogramming of the three analysis ranges and the calibration range (including impurity gas, background gas, low end of range, high end of range, and % or ppm units). Original programming is usually done at the factory according to the customer's application. It must be done through the RS-232 port using a computer running a terminal emulation program.

Note: It is important to distinguish between this *System* programming subfunction and the *Range* button function, which is an operator control. The Set Range Screen of the *System* function allows the user to DEFINE the upper and lower limits of a range AND the application of the range. The *Range* button function only allows the user to select or define the limits, or to select the application, but not to define the application.

Normally the Model 2010B is factory set to default to manual range selection, unless it is ordered as a single-application multiple-range unit (in which case it defaults to autoranging). In either case, autoranging or manual range selection can be programmed by the user.

In the autoranging mode, the microprocessor automatically responds to concentration changes by switching ranges for optimum readout sensitivity. If the upper limit of the operating range is reached, the instrument automatically shifts to the next higher range. If the concentration falls to below 85% of full scale of the next lower range, the instrument switches to the lower range. A corresponding shift in the DC concentration output, and in the range ID outputs, will be noticed.

The autoranging feature can be overridden so that analog output stays on a fixed range regardless of the contaminant concentration detected. If the concentration exceeds the upper limit of the range, the DC output will saturate at 1 V dc (20 mA at the current output).

However, the digital readout and the RS-232 output of the concentration are unaffected by the fixed range. They continue to read beyond the full-scale setting until amplifier saturation is reached. Below amplifier saturation, the overrange readings are accurate UNLESS the application uses linearization over the selected range.

To program the ranges, you must first perform the four steps indicated at the beginning of section 4.8 *Programming*. You will then be in the second *System* menu screen.

MODEL APPLICATION
SELF_TEST ALGORITHM

Use the <> arrow keys again to move the blinking to APPLICATION and press *Enter*.

```

Sel rng to set appl :
-> 01 02 03 CAL <-

```

Use the $\Delta\nabla$ arrow keys to increment/decrement the range number to 01, 02, 03, or CAL, and press *Enter*.

```

Imp: H2 Bck: N2
FR:0 TO:10 %

```

Use the <> arrow keys to move to Imp: (impurity), Bck: (background), FR: (from—lower end of range), TO: (to—upper end of range), and PPM or %.

Use the $\Delta\nabla$ arrow keys to increment the respective parameters as desired. Press *Enter* to accept the values and return to *Analyze* mode. (See note below.) Repeat for each range you want to set.

Note: The ranges must be increasing from low to high, for example, if Range 1 is set to 0–10 % and Range 2 is set to 0–100 %, then Range 3 cannot be set to 0–50 % since that makes Range 3 lower than Range 2.

Ranges, alarms, and spans are always set in either percent or ppm units, as selected by the operator, even though all concentration-data outputs change from ppm to percent when the concentration is above 9999 ppm.

Note: When performing analysis on a fixed range, if the concentration rises above the upper limit as established by the operator for that particular range, the output saturates at 1 V dc (or 20 mA). However, the digital readout and the RS-232 output continue to read regardless of the analog output range.

To end the session:

If started with the RS-232, send:

```

st<enter>
st<enter>

```

to the analyzer from the computer.

If started through the front panel, turn the instrument off and back on. Press the *Enter* key twice to return to the *Analyze* mode.

4.8.2 The Curve Algorithm Screen

The Curve Algorithm is a linearization method. It provides from 1 to 9 intermediate points between the ZERO and SPAN values, which can be normalized during calibration, to ensure a straight-line input/output transfer function through the analyzer.

Each range is linearized individually, as necessary, since each range will usually have a totally different linearization requirement. **Before setting the algorithm curve, each range must be Zeroed and Spanned.**

To linearize the ranges, you must first perform the four steps indicated at the beginning of section 4.8 *Programming*. You will then be in the second *System* menu screen.

```
MODEL APPLICATION
SELF_TEST ALGORITHM
```

4.8.2.1 Checking the linearization

From the *System* Function screen, select ALGORITHM, and press *Enter*.

```
Sel rng set algo
-> 01 02 03 <-
```

Use the <> keys to select the range: 01, 02, or 03. Then press *Enter*.

```
Gas use: H2 - N2
Range: 0 -10 %
```

Press *Enter* again.

```
Algorithm setup:
VERIFY SETUP
```

Select and *Enter* VERIFY to check whether the linearization has been accomplished satisfactorily.

```
Dpt INPUT OUTPUT
0 0.00 0.00
```

The leftmost digit (under Dpt) is the number of the data point being monitored. Use the $\Delta \nabla$ keys to select the successive points.

The INPUT value is the input to the linearizer. It is the simulated output of the analyzer. **You do not need to actually flow gas.**

The OUTPUT value is the output of the linearizer. It should be the ACTUAL concentration of the span gas being simulated.

If the OUTPUT value shown is not correct, the linearization must be corrected. Press *ESCAPE* to return to the previous screen. Select and Enter SET UP to Calibration Mode screen.

```
Select algorithm
mode : AUTO
```

There are two ways to linearize: AUTO and MANUAL: The auto mode requires as many calibration gases as there will be correction points along the curve. The user decides on the number of points, based on the precision required.

The manual mode only requires entering the values for each correction point into the microprocessor via the front panel buttons. Again, the number of points required is determined by the user.

Note: Before performing section 4.8.2 or 4.8.2.3, you must check to ensure that your calibration gases or points are between low end and high end of the range setup. All correction points must be between Zero and Span concentrations. Do not enter Zero and Span points as part of the correction.

4.8.2.2 Manual Mode Linearization

To linearize manually, you must have previous knowledge of the nonlinear thermal-conductivity characteristics of your gases. You enter the value of the differential between the actual concentration and the apparent concentration (analyzer output). Analytical Instruments has tabular data of this type for a large number of gases, which it makes available to customers on request. See Appendix for ordering information. To enter data:

From the *System* Functions Screen—

1. Use < > to select ALGORITHM , and *Enter*.
2. Select and *Enter* SETUP.
3. *Enter* MANUAL from the Calibration Mode Select screen.

```
Dpt INPUT  OUTPUT
  0  0.00  0.00
```

The data entry screen resembles the verify screen, but the gas values can be modified and the data-point number cannot. Use the < > keys to toggle between the INPUT and OUTPUT fields. Use the $\Delta \nabla$ keys to set the value for the lowest concentration into the first point. Then press *Enter*.

After each point is entered, the data-point number increments to the next point. Moving from the lowest to the highest concentration, use the $\Delta \nabla$ keys to set the proper values at each point.

Dpt	INPUT	OUTPUT
0	0.00	0.00

Repeat the above procedure for each of the data points you are setting (up to nine points: 0-8). Set the points in unit increments. Do not skip numbers. The linearizer will automatically adjust for the number of points entered.

When you are done, Press *ESCAPE*. The message, Completed. Wait for calculation, appears briefly, and then the main *System* screen returns.

To end the session:

If started with the RS-232, send:

```
st<enter>
st<enter>
```

to the analyzer from the computer.

If started through the front panel, turn the instrument off and back on. Press the *Enter* key twice to return to the *Analyze* mode.

4.8.2.3 Auto Mode Linearization

To linearize in the Auto Mode, you must have on hand a separate calibration gas for each of the data points you are going use in your linearization. First, the analyzer is zeroed and spanned as usual. Then, each special calibration gas, for each of the intermediate calibration points, is flowed, in turn, through the sensor. As each gas flows, the differential value for that intermediate calibration point is entered from the front panel of the analyzer.

Note: The span gas use to span the analyzer must be >90% of the range being analyzed.

Before starting linearization, perform a standard calibration. See section 4.4. To enter data:

From the *System* Functions screen—

1. Use < > to select ALGORITHM , and *Enter*.
2. Select and *Enter* SETUP.
3. *Enter* AUTO from the Calibration Mode Select screen.

The Auto Linearize Mode data entry screen appears.

```
1.95 % H2 - N2
Input(0) :2.00
```

5. Use the $\Delta\nabla$ keys to set the proper value of calibration gas, and *Enter*. Repeat this step for each cal-point number as it appears in the Input (x) parentheses.
6. Repeat step 5 for each of the special calibration gases, from the lowest to the highest concentrations. Press *Escape* when done.

To end the session:

If started with the RS-232, send:

st<enter>

st<enter>

to the analyzer from the computer.

If started through the front panel, turn the instrument off and back on.

Press the *Enter* key twice to return to the *Analyze* mode.

4.9 Special Function Setup

4.9.1 Output Signal Reversal

Some applications require a reversal of the output signals in order for the 4-20mA and 0-1 V DC output signals to correspond with the low and high end of the concentration range. For example, if an application involves the analysis of 85% oxygen in a background of argon by measuring the thermal conductivity of the binary gas, the analyzer would normally be set up so that the 100% oxygen (0% argon) concentration would correspond to the zero level (4mA 0 V) of the output signal. Then, 85% oxygen (15% argon) would correspond to 20mA (1 V) in the signal output.

It may be convenient for the user to have the outputs reversed so that the 85-100% oxygen level outputs a 4-20mA (0-1 V) signal respectively. This can be accomplished by reversing the data input to the custom settings. Not all applications will require a reversing function, however, if this is desirable, it must be specified at the time of purchase or alternatively, by substituting a linearizing PC board with the reversal information contained therein. Contact the factory for further information.

4.9.2 Special - Inverting Output

NOTE: If the unit has a range or ranges that specified >0 unit setup for inverting.

The steps are:

1. Press **RANGE** key.

2. Use **LEFT/RIGHT** key to move to the range that is specified as inverting output.
3. Press and hold **DOWN** key for approximately 5 to 7 seconds.
4. Press **ENTER** key.

NOTE: If the inverting has been setup, "i" shall display on the left bottom corner. Otherwise, the left bottom corner display "n".

If more than one range is specified an inverting output, repeat steps 1 to 4.

4.9.3 Special - Polarity Coding

NOTE: This setup will be identified only when performing *GAS TEST* or calculation. Formula 1 will determine which range(s) will require polarity coding.

If the analyzer indicates a negative concentration with proper span gas or formula 1 indicates a negative value, set the S1 accordingly to the table below:

Close S1-5 range 1

Close S1-6 range 2

Close S1-7 range 3

Close S1-8 cal range

Press I/O to restart the system.

4.9.4 Special - Nonlinear Application Gain Preset

NOTE: This section apply during *GAS TEST* routine for the unit that has more than one range install with nonlinear output application.

The steps are as follows:

1. Set unit range to lowest range reading.
2. Using the computer generated settings for the controller, adjust the controller settings for the maximum span gas output.
3. Press **SPAN** key. Select **AUTO** mode and setup the setting to span level. Press **ENTER** key to span.
4. Set range switch to next range.
5. Press **SPAN** key.

6. Press and hold the **RIGHT** key for approximate 5 to 7 seconds.
7. Select **AUTO** and set the reading to span gas level. Press **ENTER** key.

Repeat steps 1 to 7 if more than two ranges need to be setup.

Maintenance

5.1 Routine Maintenance



Aside from normal cleaning and checking for leaks at the gas connections, routine maintenance is limited to replacing fuses, and recalibration. For recalibration, see Section 4.4 *Calibration*.



WARNING: SEE WARNINGS ON THE TITLE PAGE OF THIS MANUAL.

5.2 System Self Diagnostic Test

1. Press the *System* button to enter the system mode.
2. Use the < > arrow keys to move to *More*, and press *Enter*.
3. Use the < > arrow keys to move to *Self-Test*, and press *Enter*.

The following failure codes apply:

Table 5-1: Self Test Failure Codes

Power

0	OK
1	5 V Failure
2	15 V Failure
3	Both Failed

Analog

0	OK
1	DAC A (0–1 V Concentration)
2	DAC B (0–1 V Range ID)
3	Both Failed

(Continued)

Preamp

0 OK - > 0 means one or more gain have a high offset, e.g. 204 means highest gain has an offset. This error is common on sealed air cells.

Cell

0 OK
1 Failed (open filament, short to ground, no power.)
2 Unbalance (deterioration of filaments, blocked tube)

5.3 VFD Display

NOTE: When a vacuum Fluorescent Display is used, it will not require contrast adjustment.

If you cannot read anything on the VFD, especially after first powering up, check that VFD cable is not loose.

5.4 Fuse Replacement

The 2010B requires two 5 x 20 mm, 1 A, T type (Slow Blow) fuses. The fuses are located inside the enclosure on the Electrical Connector Panel, as shown in Figure 5-1. To replace a fuse:

1. Disconnect the Unit from its power source.
2. Place a small screwdriver in the notch in the fuse holder cap, push in, and rotate 1/4 turn. The cap will pop out a few millimeters. Pull out the fuse holder cap and fuse, as shown in Figure 5-1.

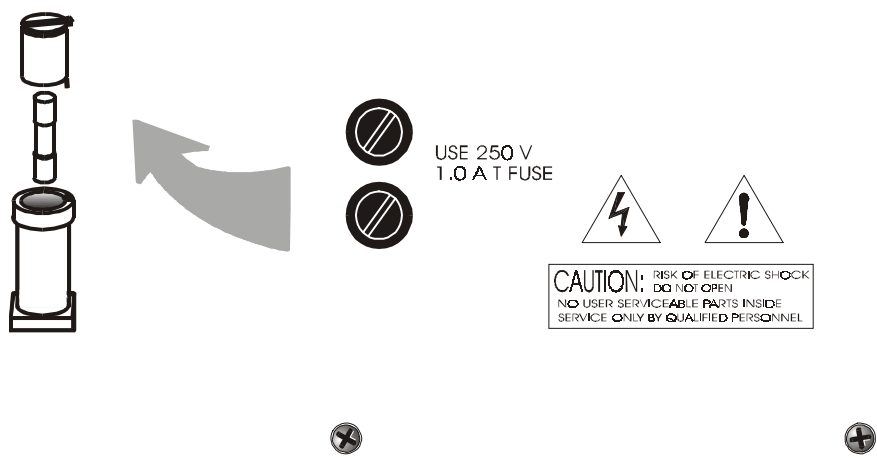

Figure 5-1: Removing Fuse Cap and Fuse from Holder

3. Replace fuse by reversing process in step 1.

Remove Power to the instrument before changing fuses.

5.5 Major Internal Components

The Interconnection Panel and the Front Panel PCBs are accessed by unlatching and swinging open the front door, as described earlier.

WARNING: SEE WARNINGS ON THE TITLE PAGE OF THIS MANUAL.

The 2010B Control Unit contains the following major components:

- Power Supply
- Preamp and Motherboard with Microcontroller
- Display Board and Displays
 - 5 digit LED meter
 - 2 line, 20 character, alphanumeric, VFD
- Rear Panel Board.

5.6 Cleaning

If instrument is unmounted at time of cleaning, disconnect the instrument from the power source. Close and latch the front-panel access door. Clean outside surfaces with a soft cloth dampened slightly with plain clean water. Do not use any harsh solvents such as paint thinner or benzene.

For mounted instruments, DO NOT wipe the front panel while the instrument is controlling your process. Clean the front panel as prescribed in the above paragraph.

5.7 Phone Numbers

Customer Service: (626) 934-1673

Environmental Health and Safety: (626) 961-9221, Extension 1592

Fax: (626) 961-2538

EMERGENCY ONLY: (24-hour pager) 1-800-759-7243
PIN # 1858192



OPERATING INSTRUCTIONS

Model 2010B

Thermal Conductivity Analyzer

Part II: Analysis Unit

NEC Type

Part Number D-70089

Model 2010B Thermal Conductivity Analyzer

Table of Contents

1 Introduction

1.1 Overview	1-1
1.2 Connections	1-1
1.3 Electrical Connector Panel	1-2

2 Installation

2.1 Unpacking the Analysis Unit	2-1
2.2 Mounting the Analysis Unit	2-1
2.3 Sample System Design	2-2
2.4 Pressure and Flowrate Regulation	2-3
2.5 VENT Exhaust	2-3
2.6 SAMPLE Gas	2-4
2.7 REFERENCE Gas	2-4
2.8 ZERO Gas	2-5
2.9 SPAN Gas	2-5
2.10 Electrical Connector Panel	2-5
2.11 Signal Wiring Recommendations	2-7
2.12 Testing the System	2-7

3 Operation

3.1 System Self Diagnostic Test	3-1
3.2 Cell Failure Checks	3-2

4 Maintenance

4.1 Routine Maintenance	4-1
4.2 Major Components	4-1
4.3 Fuse Replacement	4-2
4.4 System Self Diagnostic Test	4-3
4.5 Cell, Heater, and/or Thermistor Replacement	4-4
4.5.1 Removing the Cell Compartment	4-4
4.5.2 Removing and Replacing the Cell Block	4-5
4.5.3 Removing the Heater and/or Thermocouple	4-6
4.5.4 Replacing the Heater and/or Thermistor	4-7

Introduction

1.1 Overview

The Analytical Instruments Model 2010B Analysis Unit is a versatile remotely controlled instrument for measuring a component gas in a background gas, or in a specific mixture of background gases.

Part I of this manual covers the Control Unit. Part II, this part, covers the Model 2010B NEC type explosion proof Analysis Unit only.

1.2 Connections

The standard 2010 Analysis Unit is housed in a NEC type housing and includes all gas connections. Figure 1-1 is a cutaway illustration of the Analysis Unit showing the Gas Connections. The gas connectors are described briefly here and in detail in the *Installation* chapter of this manual.

NOTE: *The version of the 2010 Analysis Unit depicted has no options.*

The gas connections found on the 2010B Analysis Unit depend on the options selected. Refer to the outline diagram in the rear of this manual for the actual configuration. These options may include gas panels with flowmeters and auto-cal or manual valves as well as flame arrestors. If you have purchased a unit with a sealed air option, there will not be any reference gas connections or flowmeter. If you have not purchased a unit with gas panel, provision must be made to provide zero and span gas to the sample in port.

- **SAMPLE IN** This is the gas input from the sample stream. This gas connection should have a flowmeter with a range of 50-200 cc/min.

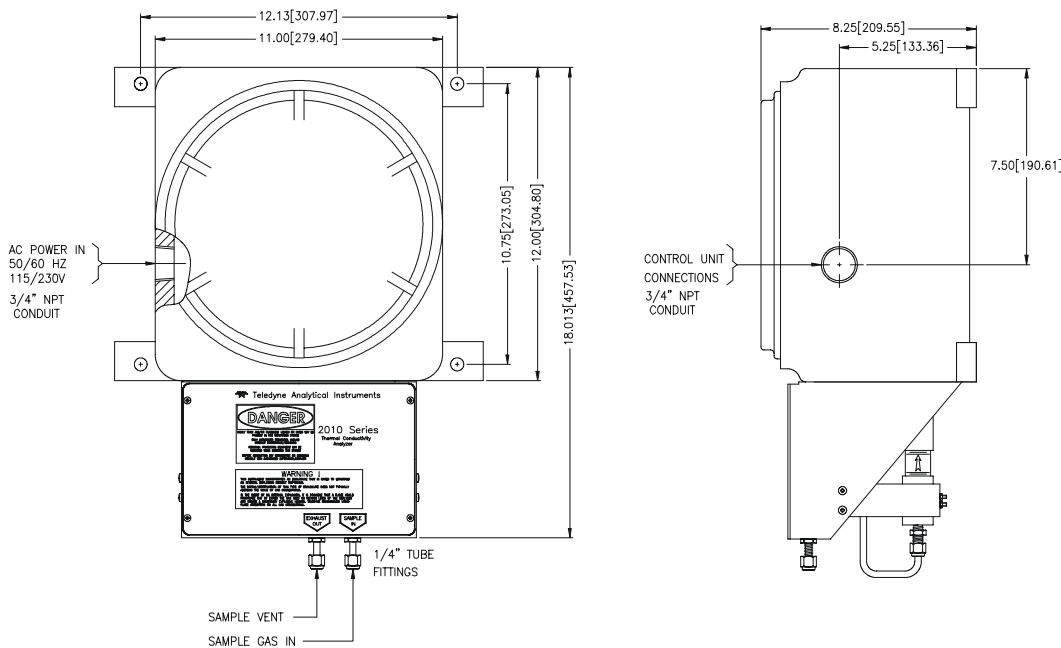

Figure 1-1: Outline Diagram of 2010B Analysis Unit

- REFERENCE IN** This is the gas input from the flowing reference gas source. This gas connector should have a flowmeter with a range of 20-100 cc/min.
- SPAN/ZERO** These gas inputs have the same requirements as the sample in connection.
- VENTS** Sample and reference gas vents must be returned to areas of equal pressure.

The actual tubing size and connection type will depend on actual options selected. See outline diagram in the rear of the manual for piping requirements.

1.3 Electrical Connector Panel

Figure 1-2 shows the internal Electrical Connector Panel. Cables enter the housing through access ports (visible in Figure 1-1), and connect to terminals inside the housing. The connectors and controls are described briefly here. They are described in detail in the *Installation*, *Operation*, and *Maintenance* chapters, as appropriate.

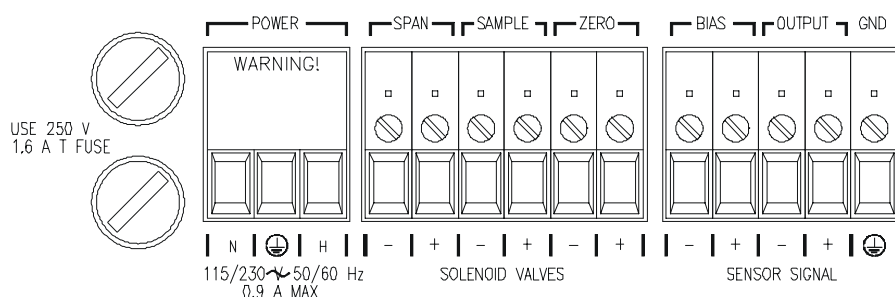

Figure 1-2: Electrical Connector/Control Panel

- Power In** Power input terminals for electric heater. Requires 110 or 220 V ac, depending on position of the Voltage Selector switch. Use 50/60 Hz.

CAUTION: Check the position of the Voltage Selector switch **BEFORE** applying power to the Power Input terminals.



- Voltage Selector** Power input selector switch for electric heater. Adjusts input requirement for 110 or 220 V ac, depending on available source voltage. Use 50/60 Hz.
- Fuses** 1.6 A, 250 V, T type, European size 5 × 20 mm fuses. Fuse 2 is on the neutral side of the line. Fuse 1 is on the hot side of the line.
- Solenoid Valves** Terminals that provide all electrical interconnections from the Control Unit to the gas control valves.
- Sensor Signal** Terminals that provide connections from the T/C sensor to the Control Unit.

Installation

Installation of the Model 2010B Analyzer includes:

1. Unpacking, mounting, and interconnecting the Control Unit and the Analysis Unit
2. Making gas connections to the system
3. Making electrical connections to the system
4. Testing the system.

2.1 Unpacking the Analysis Unit

The analyzer is shipped with all materials needed to install and prepare the system for operation. Carefully unpack the Analysis Unit and inspect it for damage. Immediately report any damage to the shipping agent.

2.2 Mounting the Analysis Unit

The Model 2010B Analysis Unit is for use in Class 1, Division 1, Groups C and D, hazardous environments (group B available). The actual class is limited by the flame arrestor option.

The standard model is designed for bulkhead mounting. Overall dimensions of the Analysis Unit will vary depending on options. The maximum footprint will be 19" × 12", and maximum height 9.4". An Outline Drawing at the back of this manual, gives the correct mounting dimensions for your unit.

Note: The housing, including the cover, protrudes 8.6 to 9.4 inches from the base on which it is mounted. Enough clearance is required in front of the cover to allow the cover to be removed.

Figure 3-1 is a view with the cover removed showing the external Gas Connector Panel and the internal Electrical Connector Panel.

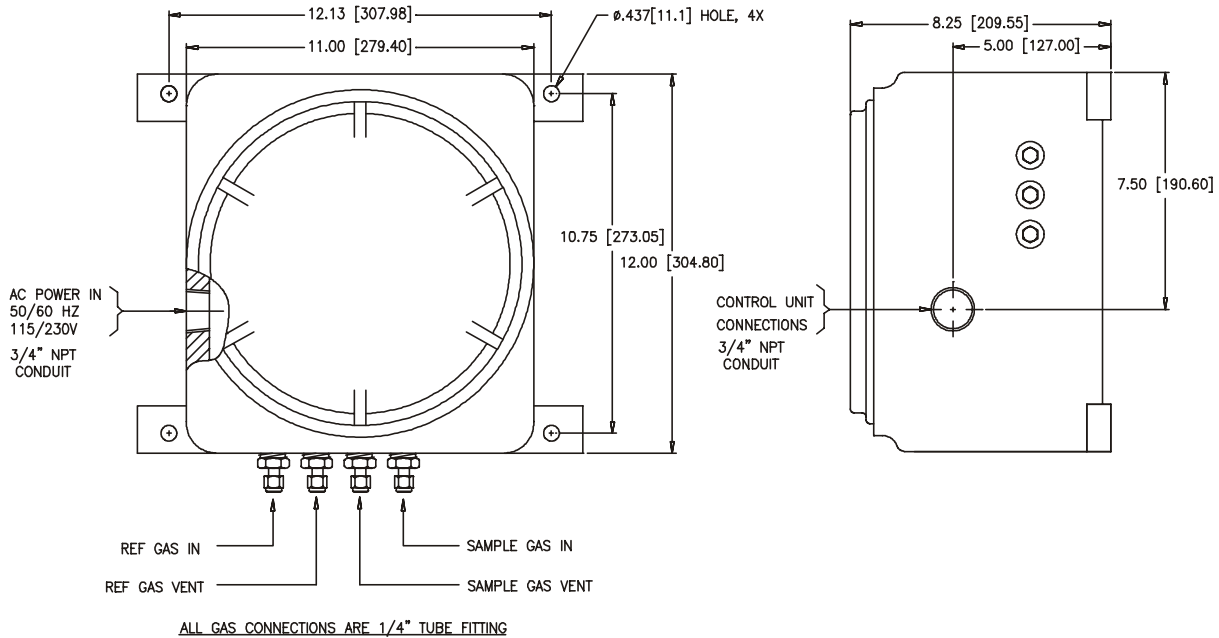

Figure 3-1: 2010 Analysis Unit with Auto-Cal & Gas Panel options

2-3 Sample System Design

Gas Connector and Selector Panels for specific applications are available at additional cost. These panels are designed to substitute a standard front panel.

For those customers wishing to incorporate their own sample system, electronic input/output ports are provided on the rear panel for the operation of solenoid valves under the complete control of the Model 2010B electronics. See section 3.3. The recommended system piping schematic is included among the drawings at the rear of the manual

For best results, use the recommended piping system. Select a flowmeter that can resolve 0.08 scfh (40-50 cc/min) for the reference path of the analyzer, and select a flowmeter that can resolve 0.3 scfh (150 cc/min) for the sample path of the analyzer.

NOTE: The sample-line pressure regulator should be installed as close to the sample point as possible to minimize sample-line lag time.

NOTE: An additional option is available for **SEALED** reference application. This option would not have the reference Gas Flow Meter, Piping and Fittings.

2-4 Pressure and Flowrate Regulation

Appropriate pressure reducing regulators must be installed at all gas supply sources. To minimize flowrate adjustments the pressure regulators on the supporting gas supply cylinders should be adjusted to provide the same output pressure as the sample line regulator.

The gas pressure at the IN input should be reasonably well regulated. Pressures between 5 and 50 psig are acceptable (10 psig is normal) as long as the pressure, once established, will **keep the flow constant** during analysis and within an acceptable range (between 0.1 and 0.4 scfh—See Note).

Note: Gases lighter than air have a flowrate higher than indicated on the flowmeter, while gases heavier than air have a flowrate lower than indicated. Values can range from one half to twice the indicated flowrate.

For example: For hydrogen or helium, set the flowrate to 0.1 scfh (50 cc/min). For carbon dioxide or argon, set the flowrate to 0.4 scfh (200 cc/min).

When installing pressure regulators on supply cylinders, crack the cylinder valves so that gas is flowing during installation. This will eliminate the most common cause of standardization-gas contamination: air trapped during assembly diffusing back into the cylinder. This procedure is particularly important in applications where impurity content of 1 to 2 % is the range of interest.

2-5 VENT Exhaust

There are two separate VENT fittings—one for the sample gas and one for the reference gas. Use $\frac{1}{4}$ inch tubing for both sample and reference vents to minimize back pressure from restricted flow.

Exhaust connections must be consistent with the hazard level of the constituent gases. Check local, state, and federal laws, and ensure that the exhaust stream vents to an appropriately controlled area if required. If not vented to the same area, both VENT lines must vent to areas with equal

ambient pressures, and pressures must vary no more than the normal barometric changes.

2-6 SAMPLE Gas

In the standard model, sample and calibration gases are introduced through the SAMPLE fitting. The gases must be Tee'd into the Sample inlet with appropriate valves.

The gas pressure in should be well regulated. The sample line pressure regulator should be installed as close to the sample line as possible to minimize sample line lag time.

If greater flow is required for improved response time, install a bypass in the sampling system upstream of the analyzer input.

2-7 REFERENCE Gas

A gas of fixed composition is needed as a reference to which the sample gas will be compared. The reference gas is normally selected to represent the main background gas of the analysis.

For most applications, a constant supply of reference gas flowing at the same rate as the sample is required for best results. However, in many cases the flow of reference gas can be slowed to about 0.08 scfh (40 cc/min) with good results.

For some applications, an optional sealed air reference is installed. In sealed-reference sensors the reference side of the detector cell is filled with air and sealed. This eliminates the need to have reference gas constantly passing through the cell.

NOTE: For instruments equipped with the optional sealed air reference, there is no REFERENCE inlet or reference VENT port.

It is highly recommended that the same cylinder of gas be used for both the REFERENCE gas and the ZERO gas.

Pressure, flow, and safety considerations are the same as prescribed for the SAMPLE gas, above.

2-8 ZERO Gas

For the ZERO gas, a supply of the background gas, usually containing none of the impurity, is required to zero the analyzer during calibration. For suppressed zero ranges the zero gas must contain the low-end concentration of the impurity.

NOTE: Because most cylinder gases are between 99.95 and 99.98% pure, it is highly recommended that the same cylinder of gas be used for both REFERENCE and ZERO gas.

NOTE: It is essential to the accuracy of the analyzer that the purity of the zero gas be known. Otherwise, when the zero control is adjusted during zero standardization, the reading will indicate the impurity content of the zero gas, rather than zero.

2-9 SPAN Gas

For the SPAN gas, a supply of the background gas containing 70-100 % of the component of interest is required as a minimum.

Note: If your analyzer range is set for inverting output, your zero gas will be at 100% of the range interest, and span will be 70 to 100% of the low end range.

If linearization is required, intermediate concentrations of the target gas in the background gas may be necessary. From one to nine separate span gases may be used, depending on the desired precision of the linearization. See chapter 4, *Operation*.

2-10 Electrical Connector Panel

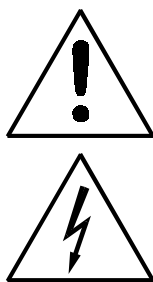

All electrical connections are made on the internal Electrical Connector Panel, inside the explosion-proof enclosure, illustrated in Figure 3-3. The signals are described in the following paragraphs. Wire size and length are given in the Drawings section at the back of this manual. To access the Panel, remove the explosion-proof cover as described in chapter 5, *Maintenance*. NEVER OPEN THE COVER IN A HAZARDOUS ATMOSPHERE. THE AREA MUST BE DECLARED TEMPORARILY SAFE BY THE PROPER AUTHORITY FIRST.

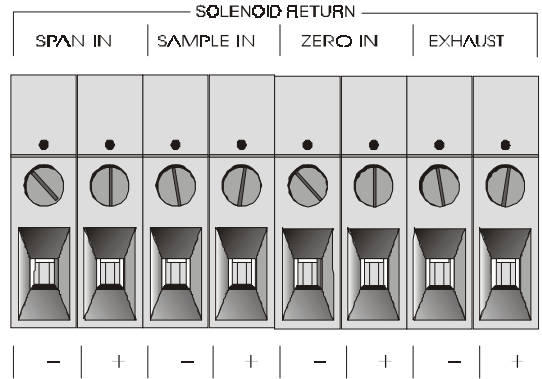

Figure 3-4: Control Unit (CU) to Analysis Unit (AU) Connector

If you use your own gas control valves, use the interconnect diagram in Figure 3-4 for the valves. The sensor and thermistor remain connected as in Figure 3-5, above. (See drawing D-73170 for wire recommendations.)

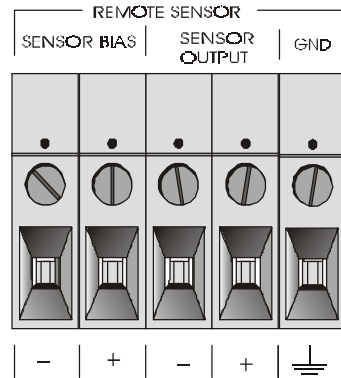

Figure 3-5: Remote Probe Connector Pinouts

The voltage from the solenoid outputs is nominally 0 V for the OFF and 15 V dc for the ON conditions. The maximum combined current that can be pulled from these output lines is 100 mA. (If two lines are ON at the same time, each must be limited to 50 mA, etc.)

If more current and/or a different voltage is required, use a relay, power amplifier, or other matching circuitry to provide the actual driving current. Note that each individual line has a series FET with a nominal ON resistance of 5 ohms (9 ohms worst case). This can limit the obtainable voltage, depending on the load impedance applied. See Figure 3-6.

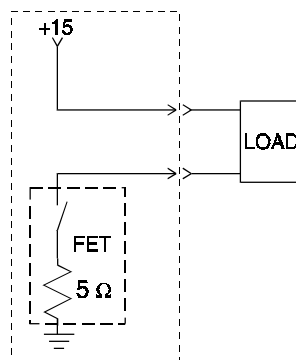

Figure 3-6: FET Series Resistance

2-11 Signal Wiring Recommendations

The signal leads are the bias and sensor leads ref fig. 3.4, and reference D-73170 interconnection diagram. The maximum interconnection distances between the 2010 control unit and the analysis unit is limited by the sensor signal requirements. The sensor has two limiting factors. The first is series resistance which is limited to a maximum of 2.5 ohms. Refer to the interconnection diagram for wire gages and distances which will meet this requirement.

The second issue is one of signal quality. At greater distances problems associated with signal degradation increases. Signal degradation problems have two major issues. The first is associated with the local installation environment. The number, proximity, and power associated with local sources of EMI radiation can not be accounted for by TAI. These issues can only be controlled by the end user. The other factor is the amplitude of the signals generated by the thermal conductivity cell. This signal level is a function of the gas composition of the gases involved. This signal level can vary from micro-volts to mili-volts dependent on application. Consult TAI for recommendations based on sample stream composition. Signal quality and operating distances can be increased by the uses of better quality shielded low loss cable. The cable configuration should be twisted pair with double shielding for best performance. The signal cable should not be run with AC power or digital signals.

2-12 Testing the System

After The Control Unit and the Analysis Unit are **both** installed and interconnected, and the system gas and electrical connections are complete, the system is ready to test. **Before** plugging either of the units into their respective power sources:

- Check the integrity and accuracy of the gas connections. Make sure there are no leaks.
- Check the integrity and accuracy of the electrical connections. Make sure there are no exposed conductors
- Check that sample pressure is between 3 and 40 psig, according to the requirements of your process.

Power up the system, and test it as follows:

1. Repeat the Self-Diagnostic Test as described in Part I, chapter 4, section 4.3.5.

Operation

3.1 System Self Diagnostic Test

The self diagnostics are run automatically by the analyzer whenever the instrument is turned on, but the test can also be run by the operator at will. During the test, internal signals are sent through the power supply, output board and sensor circuit automatically. The return signal is analyzed, and at the end of the test the status of each function is displayed on the screen, either as OK or as a number between 1 and 3. (See Table 4-1 for number code.)

Note: Remote Probe connector must be connected to the Analysis Unit, or sensor circuit will not be properly checked.

Instructions for running self diagnostics are repeated here for your convenience:

1. Press the *System* button to enter the system mode.
2. Use the < > arrow keys to move to *More*, and press *Enter*.
3. Use the < > arrow keys to move to *Self-Test*, and press *Enter*.

During preamp testing there is a countdown in the lower right corner of the screen. When the testing is complete, the results are displayed.

Power: OK Analog: OK
Preamp: 3

The following failure codes apply:

Table 4-1: Self Test Failure Codes

Power	
0	OK
1	5 V Failure

- 2 15 V Failure
- 3 Both Failed

Analog

- 0 OK
- 1 DAC A (0–1 V Concentration)
- 2 DAC B (0–1 V Range ID)
- 3 Both Failed

Preamp

- 0 OK - > 0 means gains of the amplifier have a high offset, e.g. 204 means the highest gain has a high offset it is common on sealed air reference.

The results screen alternates for a time with:

Press Any Key
To Continue...

Then the analyzer returns to the initial System screen.

3.2 Cell Failure Checks

Cell failure is covered in detail in Part I: *Control Units*, section 4.4.1.3, *Cell Failure*. Cell replacement is covered Part II: *Analysis Units* chapter 5, *Maintenance*.

Maintenance

4.1 Routine Maintenance



Aside from normal cleaning and checking for leaks at the gas connections, routine maintenance is limited to recalibration.



Self-diagnostic testing of the system and fuse replacement in the Control Unit are covered in Part I, chapter 5 of this manual. For recalibration, see Part I, section 4.4 *Calibration*.

WARNING: SEE WARNINGS ON THE TITLE PAGE OF THIS MANUAL.

4.2 Major Components

The internal components are accessed by rotating the explosion-proof housing cover counterclockwise several turns until free. See Figure 4-1, below.

WARNING: SEE WARNINGS ON THE TITLE PAGE OF THIS MANUAL.

The 2010B Analysis Unit contains the following major components:

- TC Cell
- Optional Auto-Cal Solenoid Assy.
- Heater Assembly
- Electrical Connector Panel
- Gas Connector Panel (external)

See the drawings in the Drawings section in back of this manual for details.

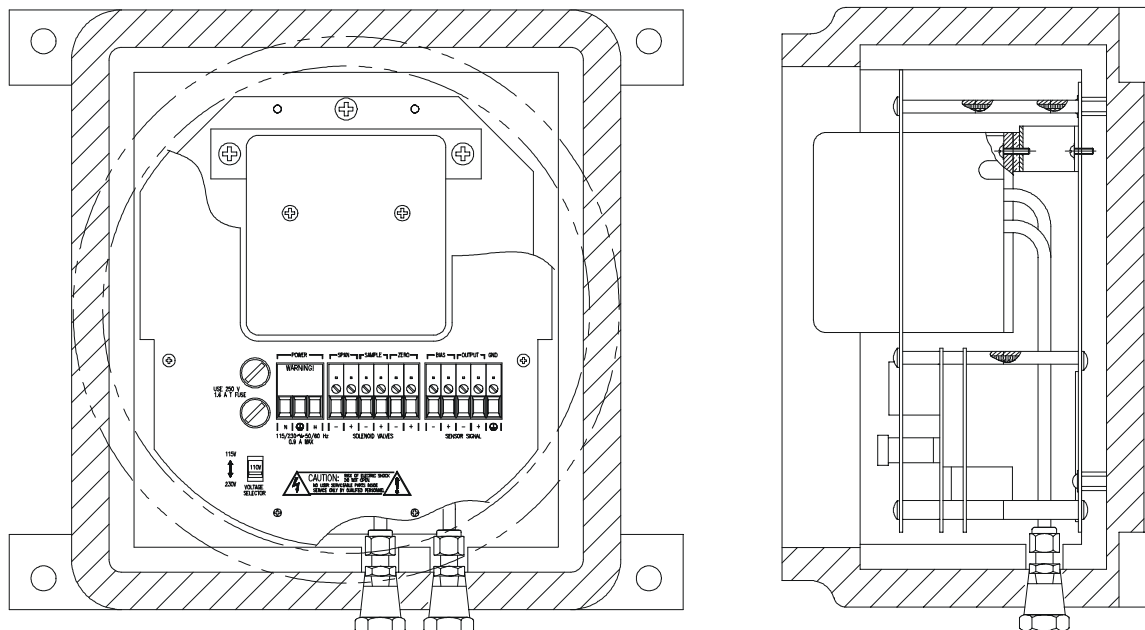

Figure 4-1: Major Components

4.3 Fuse Replacement

The 2010B Analysis Unit requires two 5 x 20 mm, 1.6 A, T type (Slow Blow) fuses. The fuses are located inside the explosion proof housing on the Electrical Connector Panel, as shown in Figure 4-2. To replace a fuse:

1. Disconnect the Unit from its power source.
2. Place a small screwdriver in the notch in the fuse holder cap, push in, and rotate 1/4 turn. The cap will pop out a few millimeters. Pull out the fuse holder cap and fuse, as shown in Figure 4-2.

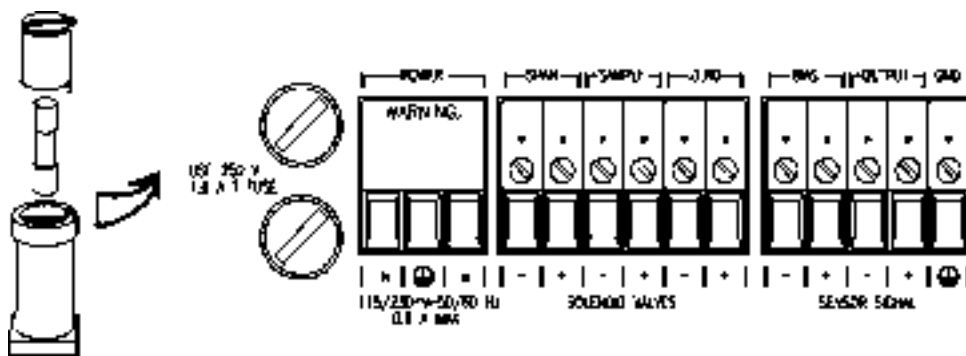

Figure 4-2: Removing Fuse Cap and Fuse from Holder

3. Replace fuse by reversing process in step 1.

4.4 System Self Diagnostic Test

1. Press the *System* button to enter the system mode.
2. Use the < > arrow keys to move to *More*, and press *Enter*.
3. Use the < > arrow keys to move to *Self-Test*, and press *Enter*.
4. Observe the error-code readings on the VFD Display screen, and check Table 4-1, below, to interpret the codes.

Table 4-1: Self Test Failure Codes

Power

0	OK
1	5 V Failure
2	15 V Failure
3	Both Failed

Analog

0	OK
1	DAC A (0–1 V Concentration)
2	DAC B (0–1 V Range ID)
3	Both Failed

Preamp

0	OK - > 0 means gains of the amplifier have a high offset, e.g. 204 means the highest gain has a high offset it is common on sealed air reference.
---	---

4.5 Cell, Heater, and/or Thermistor Replacement

The Thermal Conductivity Cell, with its Heater and Thermistor, is mounted inside the insulated cell compartment, inside the analysis unit. To remove these components, you must first remove screw on the cover, and the customer interface.

4.5.1 Removing the Cell Compartment

WARNING: IF THE MODEL 2010B ANALYZER HAS BEEN USED WITH TOXIC GASES, FLUSH IT THOROUGHLY BEFORE PERFORMING THIS PROCEDURE.

WARNING: DISCONNECT ALL POWER TO THE MODEL 2010B BEFORE PERFORMING THIS PROCEDURE.

Remove the t/c cell as follows:

- a. Verify that the power has been removed from the analysis unit prior to removing cover.
- b. Verify that the analysis unit is free from any toxic gas prior disconnecting any plumbing.
- c. Remove the screw on lid and the six #6 screws securing the interface cover panel.
- d. Remove the cover panel and the four 3/4" #6 stands-off securing the 1st interface PCB.
- e. Remove the 1st PCB and the four 7/16" #6 stand-off securing the 2nd interface PCB.
- f. Unplug the heater from J3, and the sensor connectors from the sensor connector J4, and J2, on the upper interface PCB. Remove the 2nd PCB. Remove the two #10 screws from the sensor retaining bracket located at the top of the sensor. Disconnect the gas fitting and remove the sensor from the analysis unit.
- g. Reassemble in the reverse order, verify that there are no gas leaks prior to returning the unit to service.

4.5.2 Removing and Replacing the Cell Block

- a. Refer to Figure 4-3, which illustrates removal of the Cell Block from the Cell Compartment. Exploded view is as seen from the top of the Cell Block.

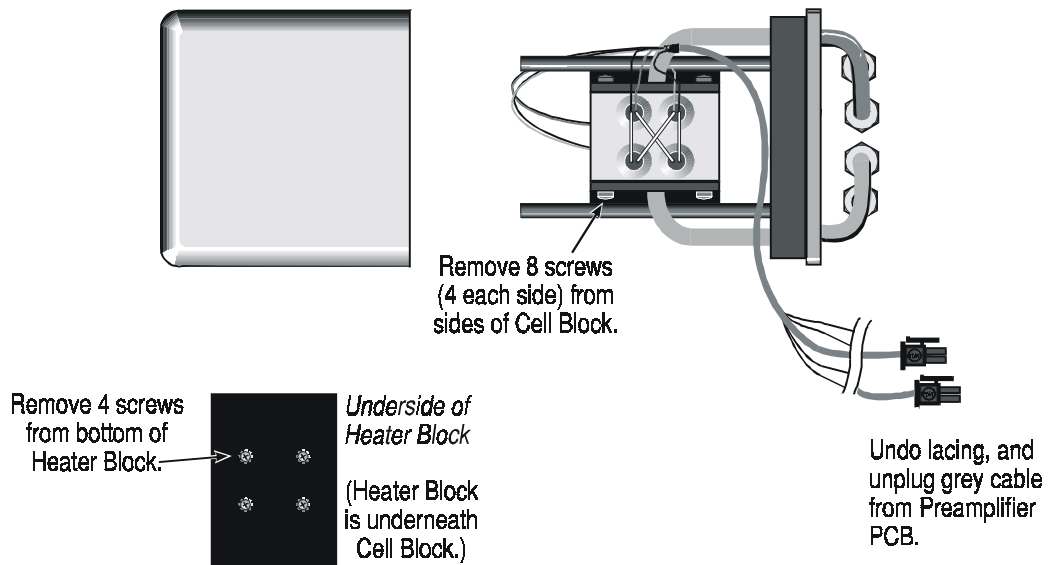

Figure 4-3: Removal of Cell from Cell Housing

- b. Remove the two screws holding the front mounting bracket—they also hold the Cell Block Cover to the Cell Block—and then pull off the cover.
- c. Turn the uncovered Cell Block assembly over so that the bottom faces you. The black rectangular block with four screws is the Heater Block. Separate the Heater Block from the Cell Block by removing the four screws. Leave the Heater Block electrical connections connected.
- d. Remove the four screws from each of the black plates that hold the Cell. The Cell is sandwiched between the plates. You should now be able to slide the Cell free.
- e. Leave the electrical connections connected at the Cell. Unlace the cabling, and unplug the grey Cell cable at the Interface PCB connector, J3. The Preamplifier PCB can be more easily accessed by removing the analyzer's rear panel.
- f. Replace the cell by reversing the above procedure, steps a through e.
- g. On analyzers with the sealed air reference option, the thermistor is epoxied to the front of the cell block.

4.5.3 Removing the Heater and/or Thermocouple

- a. Refer to Figure 4-4, which illustrates removal of the Thermistor and/or Heater from the Cell Compartment. Exploded view is as seen from the bottom of the Cell Block.

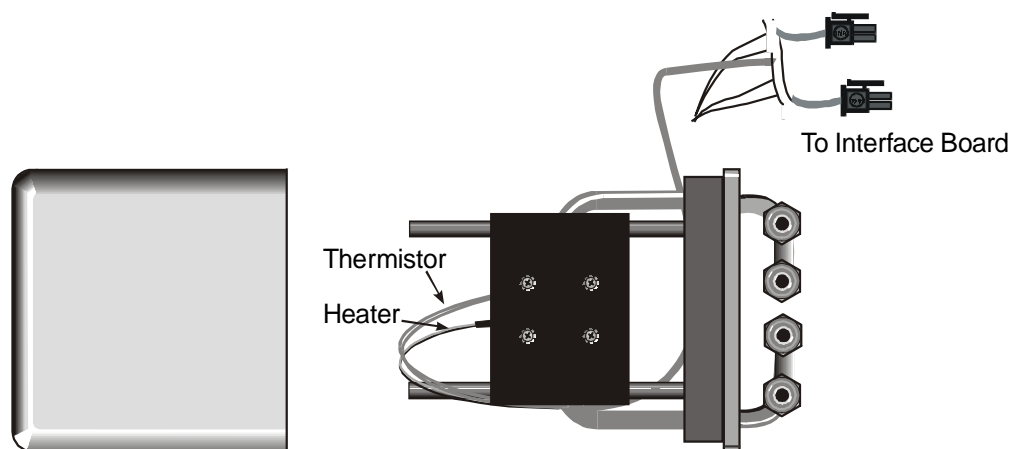

Figure 4-4: Removing the Heater and/or Thermocouple

- b. Remove the two screws holding the front mounting bracket—they also hold the Cell Block Cover to the Cell Block—and then pull off the cover.
- c. Turn the uncovered Cell Block assembly over so that the bottom faces you. The black rectangular block with four screws is the Heater Block.
- d. The Heater is fastened to the Heater Block by a set screw as well as the silicone sealing compound. The Thermistor is fastened only by the silicone sealer. **(NOTE: On units with sealed air reference option, the thermistor is epoxied to the front on the cell.)**
 - (1) To remove the Heater, use a $1/16$ " Allen wrench to loosen the Thermistor set screw. Then, grasp BOTH Heater wires firmly, and pull the Heater slowly out of the Heater Block, breaking the silicone seal. Do not allow any foreign matter to enter the empty duct.
 - (2) To remove the Thermistor, grasp BOTH Thermistor wires firmly, and pull the Thermistor slowly out of the Heater Block, breaking the silicone seal. Do not allow any foreign matter to enter the empty duct.
- e. Undo the cable lacing and separate the Heater/Thermistor wires. Then, disconnect the wires from the interface PCB.

4.5.4 Replacing the Heater and/or Thermister

- a. To replace the Heater and/or Thermister, coat the new element with silicone sealing compound, and insert it into the duct.

CAUTION: The larger duct is for the Heater element, and the smaller duct is for the Thermocouple.

- b. Enough sealing compound should be on the element to spill over and seal around the wire where it enters the duct. Smooth the outer seal and remove any excess. **(NOTE: On unit with the sealed air reference option, the thermistor is epoxied to the front of the t/c cell.)**
- c. Reassemble the Cell Compartment by reversing the procedure in section 4.5.3. Then relace the cabling.
- d. Reinstall the Assembled Cell Compartment by reversing the procedure in section 4.5.1. Then reconnect the wires to J2 on the interface PCB.

OPERATING INSTRUCTIONS

Models 2010B

Thermal Conductivity Analyzer

Appendix

Bulkhead Mount Control Unit, PN D70845
NEC Type Analysis Unit, PN D70089
NEC Type Analysis Unit, PN D70147

Contents

A-1 Model 2010B Specifications A-3
A-2 Recommended 2-Year Spare Parts List A-5
A-3 Drawing List A-6

Appendix

A-1 Specifications

Ranges: Three ranges plus a cal range, field selectable within limits (application dependent) and Auto Ranging

Display: 2 line by 20 alphanumeric VFD accompanied by 5 digit LED display

Accuracy: $\pm 1\%$ of full scale for most binary mixtures at constant temperature

$\pm 5\%$ of full scale over operating temperature range once temperature equilibrium has been reached

Response Time: 90% in less than 50 seconds

System Operating

Temperature: 32°F to 122°F (0 - 50°C)

Sensor Type: Standard TC cell (4-filament detector)

Signal Output: Two 0-1 VDC (concentration and range ID)
Two 4-20 mADC isolated (concentration and range ID)

Alarm: Two fully programmable concentration alarm set points and corresponding Form C, 3 amp contacts.

One system failure alarm contact to detect power, calibration, zero / span and sensor failure.

System Power

Requirements: Ex-Proof Analysis Unit 110 or 220 VAC, 50-60Hz. (Internal Switch selectable)

Control Unit: Universal Power 85-250 VAC 47-63Hz.

Cell Material: Nickel plated brass block with nickel alloy filaments and stainless steel end plates

O/P Interface: Full duplex RS-232, implement a subset of Tracs Command

Mounting:

Standard: General purpose NEMA-4 Bulkhead mounted Control Unit

Bulk Head mount Analysis Unit

Options: General purpose relay rack mounted to contain either one or two in a 19" relay rack mountable plate

* *Other configurations, including a totally explosion-proof, are available*

Dimensions:

Control Unit: 15.75"H x 11.75"W x 8.5"D

Analysis Unit: 13.6"W x 18.1"H x 8.25"D

Control Unit: General Purpose Flush Panel Mounting

Analysis Unit: Explosion Proof Enclosure is UL and CSA Listed for Class 1, Division 1, Groups B, C, D Service. Nema 4/7 rated. (Actual Group Rating is dependent on options selected)

Watted Parts: 316SS (except cell) standard version.

(Auto-Cal or Gas Panel option include viton seals. The standard flowmeter includes viton seals, SS valves, glass metering tube in an acrylic block).

A-2 Recommended 2-Year Spare Parts List

<i>Qty</i>	<i>Part Number</i>	<i>Description</i>
1	D67472	Back Panel Board
1	C62371B	Front Panel Board
1	C65098A	Preamplifier Board
1	C62365D	Main Computer Board
1	D70082	Customer Interface PCB Assy (AU)
1	D67651	Std. T/C Cell Assy. (Brass + SS)
2	F768	Fuse 1.6A (Analysis Unit)
1	D64849B	2010 Front Door w/overlay
2	F1275	Fuse, 1 A, 250V, 5x20mm, T- Slo-Blo
1	D65295B	Customer Interface PCB (CU)

* Order one type only: US or European, as appropriate.

Note: Orders for replacement parts should include the part number (if available) and the model and serial number of the instrument for which the parts are intended.

Orders should be sent to:

TELEDYNE Analytical Instruments

16830 Chestnut Street
City of Industry, CA 91749-1580

Phone (626) 934-1500

Fax (626) 961-2538

Web: www.teledyne-ai.com

or your local representative.

A-3 Drawing List

C70381	Outline Drawing (Standard & Auto-Cal option -C)
D70117	Piping Diagram
C70146	Outline Diagram (AU Auto-Cal Valve and Gas Panel -C-L)
C70335	Outline Diagram (gas panel option -L)
D70081	Schematic Diagram, Interface Board
D-73170	Interconnection Diagram